

RTU32S

RTU32S Series – Small Compact Utility RTU

Data Sheet
40270 v1.05 / July 7th, 2014

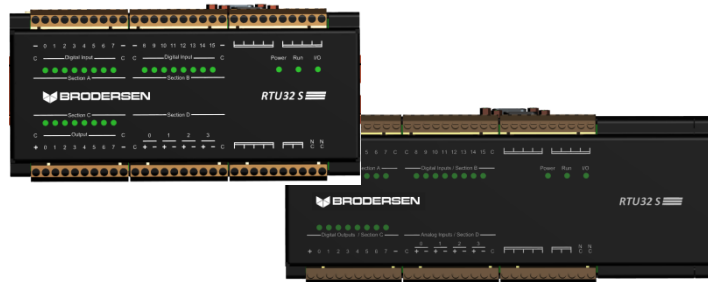



INTRODUCTION

Brodersen Small Compact RTU32S Series with RTU/PLC functionality.

The RTU32S series is based on an embedded 32-bit industrial platform providing flexible RTU functionality for smaller remote applications in the utility and infrastructure markets.

Physical communication interfaces includes LAN 10/100MBit/s, COM ports and USB ports. The RTU32S offers support for optional internal or external communication devices like data radios, GSM/GPRS/3G, Wi-Fi, dial-modems etc. makes it the perfect future proof solution for new application designs – also perfect for mounting in areas where there is no hardwired communication facilities.

RTU32S support a variety of standard and open drivers such as Modbus, IEC60870 and DNP3. In addition it includes the fast and event based Binding protocol for communication between multiple RTU32S – a fast and reliable way to distribute time stamped data between any Brodersen RTU32s in the network.

The RTU32S has a web server configuration and RTU functions, control and communication is configured in the IEC61131 PLC development tool WorkSuite.

RTU32S is supplied in a robust aluminum enclosure for DIN rail mounting and the measures of the module are (H) 80mm, (W) 178 or 226mm and (D) 80mm.

The RTU32S series is available in power supply configuration with 10-30VDC, 20-60VDC, 90-265 VAC/DC. UPS option is available through Brodersen external UPS power supply module UCS-CHRxxx/UCS-58.

The RTU32S is available with a range of integrated I/O options – 28IO and 16DIO. In addition it supports I/O expansion via the Brodersen I/O LocalBus.

FEATURE LIST

- Small Compact RTU with or without integrated I/O and communication device.
- Reliable Real Time Operating System.
- Communication Protocols Supported;
 - Full Modbus suite.
 - IEC60870-5-101/103/104 Protocol.
 - DNP3 Slave.
 - Binding - Global Distribution and Subscription of Event Based Time Stamped Variables.
- Communication Protocols in the pipeline;
 - DNP3 Master.
- Communication interfaces; 1 x Ethernet and 3 x RS232 COM.
- Integrated I/Os and I/O Expansion via Brodersen LocalBus
- Full EN/IEC61131 PLC runtime – also used for special and flexible data manipulation.
- Wide range of power supply options
- Full remote management with configuration, programming and flexible distribution of all levels of software from and to RTUs on remote locations.



VERSIONS / ORDERING CODES

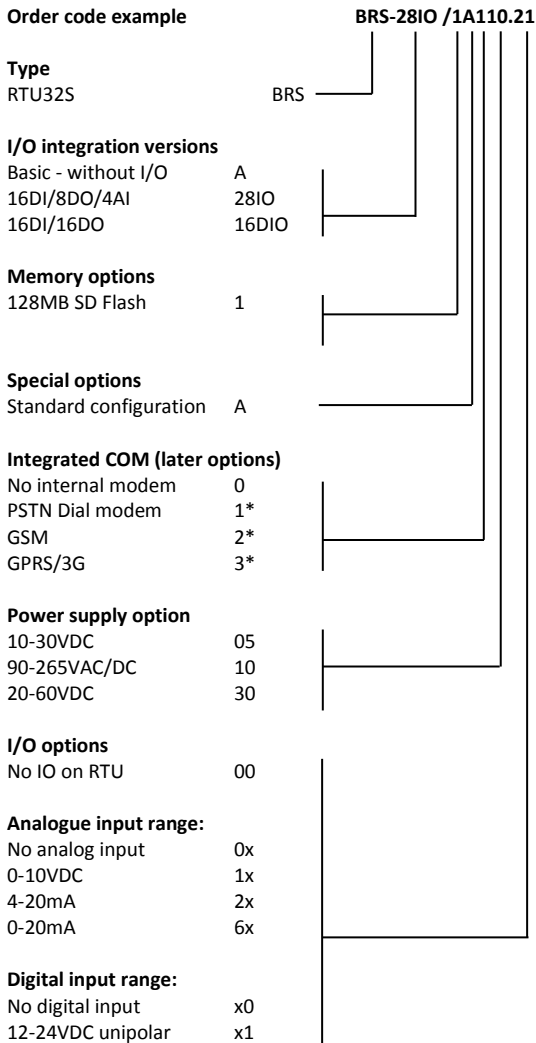

*) Future option

TECHNICAL DESCRIPTION

Software – General

RTU32S open Real Time Operating System is Windows CE Embedded 6. It offers access and support to a wide range of standard network protocols like TCP/IP, UDP, HTML, FTP, SNTP, SMTP etc. Compared to other conventional Windows OS, the real time based Windows CE Embedded does support the capacity to handle the necessary priorities for fast PLC runtime execution and parallel multiple communication task handling.

Software – Basic Setup and Configuration

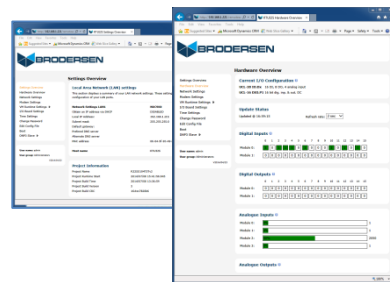

Basic configuration using Internet Browser connected to the integrated WebServer. Configuration include e.g. basic settings for network communication, I/O configuration and SNTP (time synchronization via Simple Network Management Protocol) etc.

The configuration also defines settings like APN, user authentication for 3G/GPRS modem connected to USB interface.

Full remote configuration and complete software update are possible via all communication interfaces.

Software – RTU Configuration and Programming

For special data manipulation, the internal PLC runtime can be programmed with the Brodersen WorkSuite that is the IEC61131 application developing tool. It supports all 5 languages; ST, FB, SFC, LD and IL.

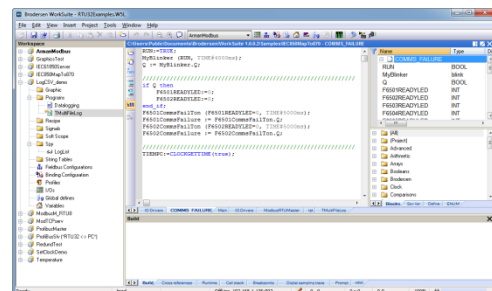

All drivers and any even low level data manipulation are handled in the PLC program. RTU PLC runtime is a very



flexible and powerful tool to use in your application development. It includes features such as;

- Fieldbus and profile editor for simple and fast driver setup.
- Free variable definition of variable from simple Booleans to advanced Arrays and Structures.
- Free program language mix, full conversion features and program part prioritizing.
- Full Simulation and debugging functions.
- Large library of ready to use functions.
- Create your own User Defined Function Blocks in PLC language or C.

Full remote programming is possible via communication interface.

Brodersen provide tools and wizards to simplify and decrease total time of application development. These tools e.g. include a complete IEC60870 Driver Configuration Tool (IEC60870CONFIG) enabling setup of an IEC60870 driver in an Excel sheet in less than 30 minutes.

Software – Communication Drivers

RTU32S support a range of standard drivers;

- IEC60870-5-101 Slave including dial functions.
- IEC60870-5-103 Master.
- IEC60870-5-104 Server.
- I/O drivers for integrated I/O and LocalBus I/O Expansion.
- ModbusRTU Master and Slave.
- ModbusTCP Client and Server.
- ModbusASCII Drivers.
- DNP3 Server/Slave
- Distributed event based Binding protocol for fast RTU to RTU communication.

Future Drivers for RTU32S;

- SNMP Agent
- DF1 Master
- DNP3 WITS Slave
- DNP3 Master

Software – I/O Drivers

RTU32S support dedicated I/O LocalBus drivers for integrated and Expansion I/O modules.

I/O Drivers includes direct I/O board definitions and variable profile assignment definitions.

Modem Control / Dial-up / Dial-in

Dial-up and dial-in functions are supported by the RTU32S. It is used for PSTN or GSM modems connected modem to the serial port of the RTU32S. It can be used for any serial communication e.g. ModbusRTU and IEC60870 serial protocols.

Real-Time / Real-Time Clock

The WinCE real-time task is used for the application program execution. Time stamps and cyclic execution are also based on the WinCE real-time clock. Time stamps are reported in milliseconds resolution. The RTU32S support clock synchronization via SNTP and utility protocols.

COM communication for NullModem, Radio and Leased Line modems

The RTU32S has implemented extended necessary data communication features for communication of ModbusRTU, serial IEC60870-5-101 etc. over serial modems and converters. The features cover detailed handshake control with timing of RTS and CTS.

3G / GPRS Modem controlled directly by RTU32S

The RTU32S support external UCM-94 3G/GPRS modem connected directly via USB Interface. Software is available to handle automatic connection to defined APN. And additional features in PLC runtime make it possible to control your connection.

Power supply options

The RTU32S offers the following power supply options; 10-30VDC, 20-60VDC and 90-265VAC/DC. If battery backed UPS functions is required, Brodersen provide the UCS-CHRxxx or UCS-58 UPS power supplies for the RTU32S Series.

All power supply option provides IO Expansion bus power for up to 600mA@12VDC.

Other interfaces

The RTU32S has two USB ports for use for 3G Modem, Ethernet converters etc.



I/O CONFIGURATIONS

The RTU32S is designed for supporting a wide range of integrated IO configurations as well as the range of Brodersen external IO Expansion modules via LocalBus RJ45 connector.

In addition the RTU32S can be used with 3rd party distributed I/O via any of the supported drivers – e.g. ModbusTCP.

Integrated I/O options

The RTU32S is available in standard I/O configurations including 28IO and 16DIO (16DI+16DO). In addition the RTU32S can be expanded to support up to a larger number of I/O. See section Optional I/O Configuration for details.

I/O Expansion



RTU32S can be used with all existing UCL type Brodersen I/O Expansion modules. No programming or configuration is required – the RTU32S supports automatically I/O configuration of Brodersen I/O Expansion modules.

The LocalBus interface includes both the reliable and well proven IO communication bus and power supply for I/O Expansion modules. RTU32S can deliver up to 600mA@12VDC for IO modules.

Please see I/O Expansion selection guide for selecting your I/O modules.

OPTIONAL I/O CONFIGURATIONS (future options)

The RTU32S Series offers flexible I/O combinations for higher quantity orders. Below are listed of optional example I/O configurations available in the RTU32S Series;

DI configurations

- 32DI** - 32 opto isolated 1- wire digital inputs 10-30VDC.
- 64DI** - 64 opto isolated 1-wiire digital inputs 10-30VDC.
- 16DI** - 16 opto isolated 2-wire digital inputs 90-125VDC.
- 32DI** - 32 opto isolated 2-wire digital inputs 90-125VDC.

DO configurations

- 32DO** - 32 opto isolated digital outputs 10-30VDC.
- 64DO** - 64 opto isolated digital outputs 10-30VDC.

Mixed DI/DO configurations

- 32DIO** - 32 opto isolated 1- wire digital inputs 10-30VDC and 32 opto isolated digital outputs 10-30VDC.

Mixed I/O configurations

- 24IO** – 16 opto isolated 1-wire inputs 10-30VDC, 4 relay outputs and 4 isolated analogue inputs 0-10V/0-20mA/ 4-20mA.

Default standard digital inputs are uni-polar 10-30VDC. Digital inputs can optionally be delivered in ranges such as 24-48VDC, 40-70VDC – in uni-polar or bi-polar configuration.

INTEGRATED MODEMS (future option)

The RTU32S Series offers optional integrated modem for remote communication. The modems supported are;

- Analogue line PSTN dial modem V32-V90.
- GSM tri-band data dial modem.
- GPRS/3G modem for online network communication.

NOTE: Until this feature is available, you can always use external modem connected via serial interfaces.



TECHNICAL SPECIFICATIONS

HARDWARE - BASICS

CPU: Nuvoton 32-bit W90P910 ARM9 200 MHz.
Memory: RAM: 64MB SDRAM. NAND Flash: 128MB. SD Card Flash disc – removable.
RTC: Integrated and battery backed RTC with 1 msec resolution. RTC accuracy: 34 ppm
Interfaces: LAN: 10/100Mbps RJ45, not isolated.
COM1 RS232, full HW handshake and up to 115.200baud, D-sub male 9 pin, not isolated.
COM2 RS232, via 3 pin screw connector with Rx, Tx and Gnd. Not isolated. Up to 115.200baud.
COM3 RS232, up to 115.200baud – D-sub male 9 pin, no isolation.
2 x USB 2.0.
I/O LocalBus for support up to 12 I/O Modules – RJ45.

RTU32S PLC RUNTIME

PLC Runtime performance:

Minimum cycle time: 40msec
Typical cycle time: 100msec
Maximum PLC variables: 2 x 20kb – calculated as sum of all variables.
Scan time internal I/O: Min. 25msec
Scan time external I/O: Min. 50msec

INDUSTRIAL I/O VERSIONS

Integrated I/O:

Standard integrated I/O versions:

28IO

16 x opto isolated digital inputs 10-30VDC.
8 x PNP opto isolated digital outputs 10-30VDC.

4 x isolated analogue Inputs 0-10V/0-20mA/4-20mA.

16DIO

16 x opto isolated digital inputs 10-30VDC.
16 x PNP opto isolated digital outputs 10-30VDC.

LocalBus I/O interface for I/O Expansion;

Support all Brodersen UCL I/O Expansion modules.

INTEGRATED DIGITAL INPUT/OUTPUT

Inputs:

Input voltage activated: 10-30VDC.
Input voltage deactivated: Max. 3VDC.
Input current: 12V DC: Typical 3mA.
24V DC: Typical 6mA.
Input delay: Typical 1ms.

Outputs:

External voltage: 10 - 30V DC.
Output voltage drop: Max. 1.5V (output activated)
Output current: Max. 0.5A.
Output peak current: Max. 5A in 1 sec.
Output leakage current (off): Max. 0.5mA.
Output delay: Max. 1ms.

Isolation

(input / output to electronics, input to output): 2kV AC.

INTEGRATED ANALOG INPUT

Inputs:

4 multiplexed analogue channels with solid state multiplexer.

Input configuration: Differential (+/-), flying capacitor type.

Table with 4 columns: Input measuring ranges, Type no. code, Voltage input, Current input. Rows include .D1 (0-10V, 0-20mA), .D2 (4-20mA), .D6 (0-20mA).

Resolution: 12 bit, 0-4095.
Input impedance: Voltage: D1: 100 kOhm.
Current: D1: 500Ohm
D2/D6:100 Ohm.

Absolute maximum ratings:

Input voltage: ±40V DC.
Input current: ±30mA DC.



Sampling interval: 250 msec.

Measuring accuracy:
At -10°-55°C; ±0.3% ± 8LSB (typically 0.1% ± 4LSB).

Linearity: Better than ± 1LSB.

Temperature stability: Better than ± 50ppm/°C

Common mode input voltage: Max. ±80V DC.

Common mode rejection ratio: Min. 60dB (typical 72dB).

Series mode rejection: Min. 30dB (50-120Hz)

Isolation (input to input): 500V.

POWER SUPPLY

The power supply ratings for the 3 options are;

Power supply type	05	10	30
Supply voltage - nominal	12-24VDC	115-230VAC/DC	24-48VDC
Supply voltage – absolute maximum input range	10-30VDC	90-265VAC/DC	20-60VDC
Mains frequency	DC	40-70Hz	DC
Power consumption (W) – max.	10W	15W	14W
Power consumption (W) – typical	4W	5W	5W
Isolation (V)	3750	3750	3750

GENERAL

LED indicators:

Digital output: One for each digital input, (red) indicating active input.

Digital output: One for each digital output, (yellow) indicating active output.

System: Indicating RTU OK (green).

I/O: Indicating I/O and local bus OK (green).

Power: Indicating power OK (green).

Run: Indication PLC runtime running (green).

COM1: Indicating Rx/Tx activity on COM1.

COM2: Indicating Rx/Tx activity on COM2.

COM3: Indicating Rx/Tx activity on COM3.

CPU: On = CPU ok

Protection: IP20

Mounting: DIN rail (EN50022) or Wall mounting (via optional mounting kit)

Housing: Black corrosion protected aluminum housing.

Dimensions & Weight:
WxHxD: 178x80x80mm in basic version
WxHxD: 226x80x80mm in version for extended I/O and modem

Weight: Approx: 0.8kg

Standards and compatibility – environmental

Ambient temperature:

Storage: -40 - +85°C
Operation: -20 - +60°C (standard), -40 - +70°C (in extended temp version).

EMC/LVD:

IEC61000-3-2:2000.
IEC61000-3-3:1995+A1.
EN55022:1998 Class A.
EN55024:1998+A1+A2.
EN61000-6-2:2005 (with reference to EN61000-4-2:1995, EN61000-4-3:2002, EN61000-4-4:2004, EN61000-4-5:1995, EN61000-4-6:2007, EN61000-4-8:1993, EN61000-4-11:2004).
IEC60950-1:2003 Safety requirements for electrical equipment for measurement and control.

Climatic:

Dry heat: IEC 60068-2-2, Test Bd, Temp. +55°C, Duration 8h.
Cold: IEC 60068-2-1, Test Ad, Temp. -10°C, Duration 8h.
Damp heat: IEC 60068-2-3, Test Ca, Temp. 40°C, RH 95%, Duration 8h.

Mechanical:

Vibration: IEC 60068-2-6, Test Fc (sinusoidal), Freq. 10-150Hz, Amp.4g, 5 sweeps in 3 orthogonal axes.
Shock: IEC 60068-2-27 (half sine), Acc. 15g, Pulse time 11msec., 3 x 6 shocks.



CIRCUIT CONFIGURATION (DIGITAL)

Input

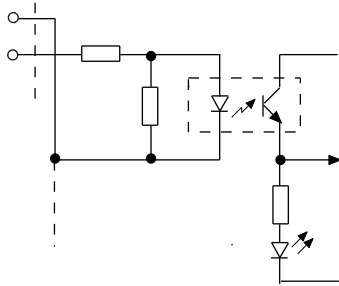

Output (PNP type only)

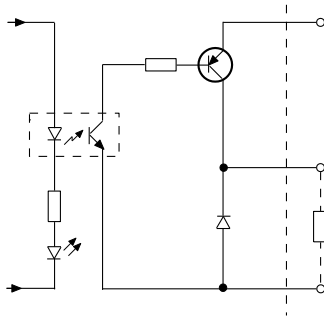

CIRCUIT CONFIGURATION (ANALOGUE)

Analogue Input

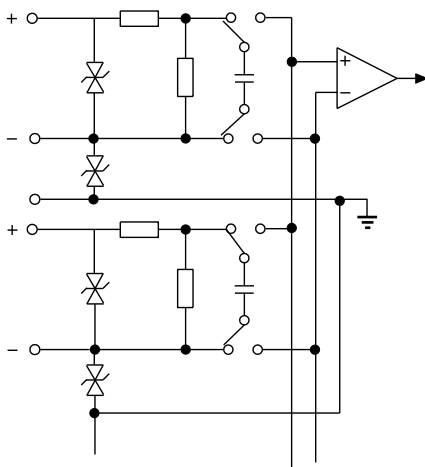

INTERFACE OVERVIEW

Top view

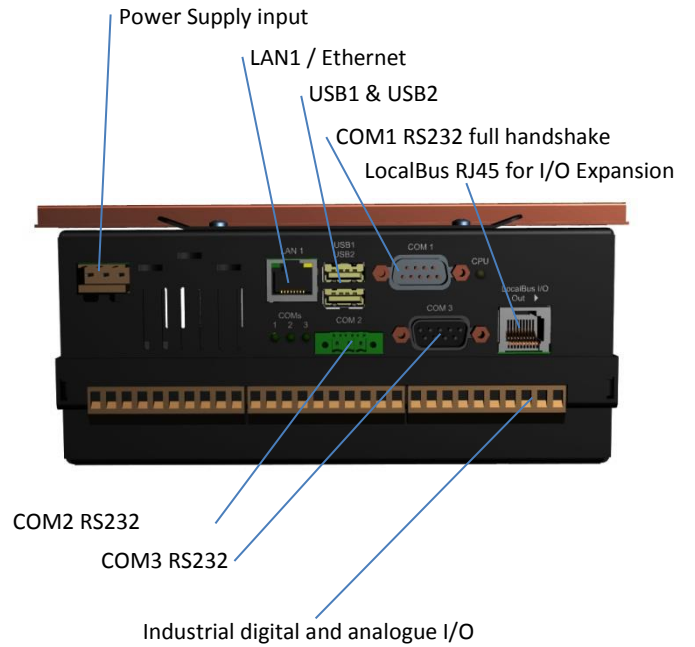

Bottom view

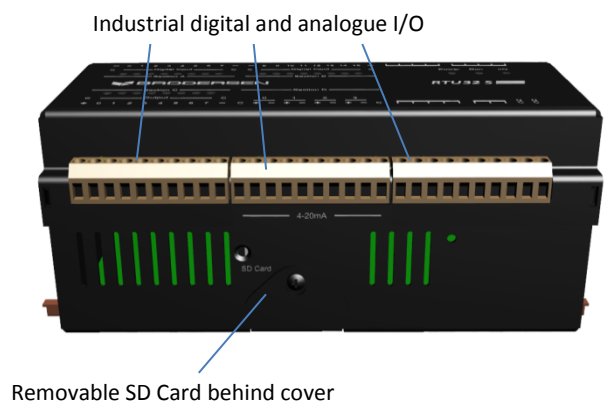

NOTE: This data sheet is subject to change without any prior notice!