

# Comparison of PRP and HSR Networks for Protection and Control Applications

**Rich Hunt**  
GE Digital Energy  
USA

**Bogdan Popescu**  
GE Digital Energy  
Canada



# Comparison of PRP and HSR Networks for Protection and Control Applications

Rich Hunt, Bogdan Popescu – GE Digital Energy

## 1. Summary

Communication requirements in substations are changing from the simpler requirements needed to support SCADA, to the more stringent requirements needed to support the advanced applications deriving from IEC 61850. Mission critical GOOSE messages and control commands must be received by subscribing devices within a specific time window to ensure the reliability of protection and control performance. RSTP-based networks may not provide adequate transmission reliability for these mission critical messages, due to network recovery time after failure of network components. IEC 62439-3 addresses this need by defining two recovery protocols that provide zero recovery time due to network configuration: Parallel Redundancy Protocol (PRP) and Highly-available Seamless Redundancy (HSR).

This paper describes the benefits and detriments of both PRP and HSR by analyzing their use in a variety of applications. Applications will include station bus and process bus applications in both large and small substations. Included is a high level discussion of capital costs, operating requirements, and operating costs of both methods.

## 2. Introduction

The protection and control system in modern substations is becoming more and more digital: therefore the performance of the protection and control system depends on successful communication of data between devices. This requires that the communications network is highly reliable and highly available. Just as with the protection and control system, the communications network needs to eliminate single points of failure. Bypassing or accounting for the failure of a network element should introduce as short a time delay in message transmission and reception as possible, with zero delay ideal.

The traditional network method for availability is to use a ring network, so any network node has two paths to communicate around the network. Network switches are connected to create a physical ring. Networks are composed of Ethernet switches that use a store and forward method to pass data, forming a virtual connection between switch ports. Ethernet switching does not permit a virtual connection that forms a complete ring, so there are always specific ports on switches configured to be virtually open. These specific “open” ports therefore won’t forward any data. This means for any data transmission there is a normal point-to-point path through the network. On the failure of a network link in this point-to-point path, the network will reconfigure to a new point-to-point path through the network by closing virtually open ports as appropriate. The basic protocol behind this is Spanning Tree Protocol (STP) as defined by IEEE 802.1D.<sup>[1]</sup> Network reconfiguration time using STP may take minutes. IEE 802.1w<sup>[2]</sup> defines Rapid Spanning Tree Protocol (RSTP), which speeds up reconfiguration time to seconds. Switch manufacturers have developed proprietary versions of RSTP,

known as “enhanced RSTP”, which speeds up reconfiguration time even faster, to hundreds of milliseconds.

For applications in the communications world, a network reconfiguration time of hundreds of milliseconds is adequate. Voice over IP still works, videos still stream, and emails are still successfully sent. For most substation communications needs, such as traditional SCADA, this level of possible time delay is acceptable. However, there are new requirements arising from new applications. GOOSE messages, sampled value (SV) messages, and some client/server control communications are mission-critical. An example is a GOOSE message containing a flag used for tripping, blocking, or unblocking. This GOOSE message must be received within carefully defined time limits that may be in the millisecond range; not hundreds of milliseconds. Sampled value messages cannot be delayed more than a few milliseconds without adversely effecting protection functions.

GOOSE reliability is based on retransmission: the message is rebroadcast and increasing intervals up to the heartbeat time. Assume a network that takes 100 ms to reconfigure, as in Figure 1. If a GOOSE message is published as this network is reconfiguring, then the only copy of this message that may go through to the subscribing device is the heartbeat message of one second; too slow for blocking signals. Sampled value messages that are delayed by more than a few milliseconds are just considered lost by the subscribing relay. A network reconfiguration time on process bus of 100 ms (6 power system cycles at 60 Hz) will result in protection being blocked for 6 to 8 cycles. So the need exists for a better availability method than the ones provided by STP, RSTP, or enhanced RSTP.

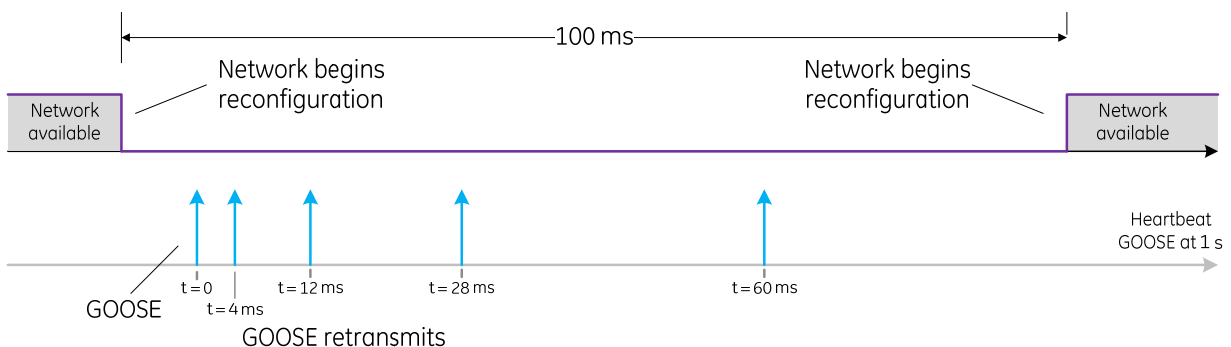

**Figure 1: GOOSE and RSTP**

The IEC 61850 Standard recognizes this need, and specifically defines in 61850-5 the tolerated delay for application recovery and the required communication recovery times for different applications and services. The tolerated application recovery time ranges from 800 ms for SCADA, to 400  $\mu$ s for sampled values. The required communications recovery times range from 400 ms for SCADA, to 0 for sampled values. In fact, as Table 1 shows, RSTP is only adequate for SCADA. All other applications and services require something better.

Table 1: IEC 61850 Tolerated Communications Delays<sup>[3]</sup>

Communicating Partners	Service	Application Recovery Tolerated Delay	Required Communication Recovery Time
SCADA to IED, Client-server	IEC 61850-8-1	800ms	400ms
IED to IED interlocking	IEC 61850-8-1	12ms (with T <sub>min</sub> set to 4ms)	4ms
IED to IED, reserve blocking	IEC 61850-8-1	12ms (with T <sub>min</sub> set to 4ms)	4ms
Protection trip excluding Bus Bar protection	IEC 61850-8-1	8ms	4ms
Bus Bar protection	IEC 61850-9-2 on station bus	< 1ms	Bumpless
Sampled Values	IEC 61850-9-2 on process bus	Less than two consecutive samples	Bumpless

It is obvious that even proprietary enhanced RSTP solutions have a recovery time orders of magnitude longer than IEC 61850 fast GOOSE requirements. The answer is to find a method that achieves “zero time” for recovery, also known as “bumpless” recovery. This high-speed recovery can be done when data traffic occurs simultaneously on multiple paths. An interruption in one path has no effect on the other one.

## 2.1. Traditional reliability methods

The traditional methods to address reliability and network reconfiguration use devices that have dual network interface ports. These methods include dual LANs and redundant LANs. Neither method is well-suited for 61850, especially for GOOSE or sample value messages.

### 2.1.1. Dual LAN

In a dual LAN configuration, the two device ports have separate MAC addresses and IP addresses. Redundancy is implemented at the session layer (Layer 5 of the OSI stack). Applications will use both ports, each connected to a different network. For IEC 61850, this requires that different GOOSE messages or sampled value messages are published to each network; and that end devices can subscribe to both messages successfully. This requires much configuration effort at end devices to successfully compare two GOOSE messages containing the same data. Also, there is no guarantee of, or provision for, any possible time delay between receiving the two GOOSE messages.

### 2.1.2. Redundant LAN

In a redundant LAN configuration, the two device ports share a common MAC address and IP address. Redundancy is implemented at the data link layer. Only one port is active at a time. Applications will use either port, and if two LANs are used, they must be connected together. Redundant LANs rely on network devices to detect a link failure, and swap over to the redundant port. This detection time can be seconds long, so redundant LANs are not adequate for GOOSE and sampled value applications. It is clear that the dual LAN network and redundant network configurations are not the right solutions for mission critical applications like GOOSE and sampled values.

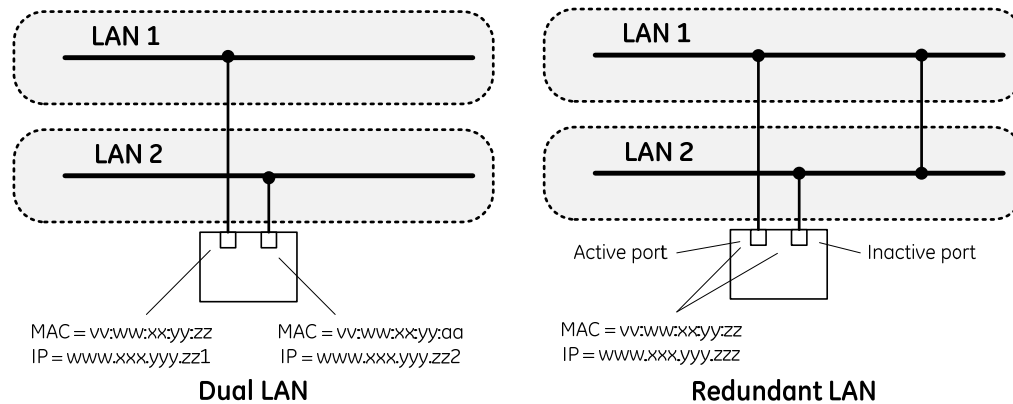

Figure 2: Dual and Redundant LANs

### 2.2. IEC 62439-3: PRP and HSR

To address this need for zero recovery time networks, IEC 61850 mandates the use of the IEC 62439-3 Standard.<sup>[4]</sup> Clause 4 of this Standard defines Parallel Redundancy Protocol (PRP) and Clause 5 defines High-Availability Seamless Redundancy (HSR). Both methods of network recovery provide “zero recovery time” with no packet loss. These are the only standard methods to ensure GOOSE and sample valued transmissions without additional delays in the case of LAN defects.

The basic concept behind PRP is that a device is connected to two independent networks. Any message this device publishes is mirrored to both networks. Subscribing devices, also connected to both networks, will accept the first version of the message received, and discard the second version. If one network link fails, the mirrored message will still go through on the second network. The two networks don't need to be identical, but they must not be connected to each other.

The basic concept behind HSR is that all devices are connected in a ring topology, without switches. Any message from the publishing device is duplicated, and sent both directions around the ring. A subscribing device accepts the first version of the message received, and discards the second version. If a network link fails, the version of the message traveling the other direction around the ring will be received and used.

Note that with both PRP and HSR, the end result is not “zero recovery time”, but is actually zero packet loss. The duplicate messages, because they use different paths, will have slightly different transmission times. With PRP, this time shouldn't be significant (in the order of microseconds). With

HSR, this time difference will be a function of the differences in the number of hops each direction around the ring. Depending on the number of hops in the ring, this difference may become fractions of milliseconds. However, this will still have no practical impact on performance. Therefore, with PRP or HSR, there should be no practical impact on applications.

### 3. Overview of PRP and HSR

Determining when to apply high availability network, and to choose between using either PRP or HSR, requires some basic understanding of how each method operates.

#### 3.1. PRP

Zero recovery time for data transmission can occur when the data appears on multiple paths simultaneously. The multiple paths of PRP are two redundant networks. These networks must be completely independent networks. The networks use standard Ethernet switches, with both managed and unmanaged switches used as appropriate. The general concept of PRP is illustrated in Figure 3. A source device publishes a PRP “C” frame that is then mirrored as the PRP “A” frame to LAN A, and as the PRP “B” frame to LAN B. A subscribing device, connected to both LANs, accepts the first frame received, and discards the second frame received. The resulting output is the PRP “D” frame. If LAN A experiences a failure, the “A” frame will not be received in a timely fashion by the destination device. However, the “B” frame will still be received as normal.

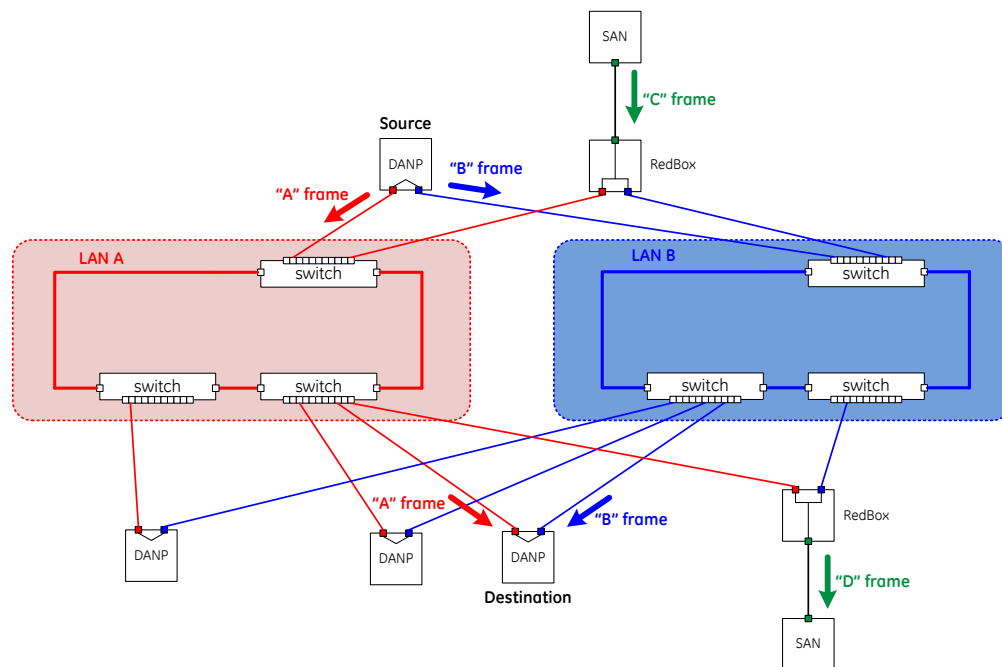

Figure 3: PRP concept

As illustrated in Figure 3, there are several different types of nodes that can attach to a PRP network. Figure 4 illustrates these nodes.

- **DANP:** a DANP is a “double attached node implementing PRP”. A DANP has two ports (port A and port B) that have the same abilities, and in particular could be used alternatively if only

one LAN would be connected. A source DANP sends the same frame over both LANs. A destination DANP receives the mirrored frames from both LANs within a certain time, consumes the first frame and discards the duplicate. The “C” frame and the “D” frame are internal to the DANP.

- **SAN:** a SAN is a “single attached node” that has only one port for the purpose of this protocol, so no special requirements apply. Bridges and Switches are SANs.
- **RedBox:** a RedBox device is used to attach SANs to a PRP network. The RedBox acts like a DANP on the PRP side. The RedBox mirrors the “C” frame published by a SAN, and creates the “D” frame from mirrored PRP messages to send to a SAN.
- **VDAN:** Virtual Doubly Attached Node (SAN as visible through a RedBox)

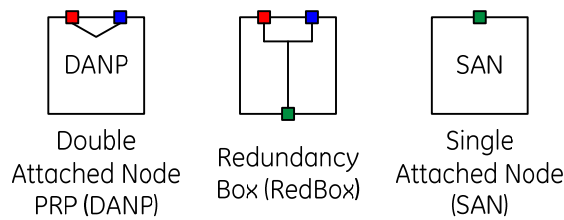

Figure 4: PRP devices

A legacy device, that does not implement PRP, is considered a SAN. It is possible to connect a SAN as a single node to either one of the networks. If the SAN device is connected in this manner, it can only communicate with other devices connected to the same network, including DANP devices. However, it is not sending PRP frames, only traditional Ethernet frames.

PRP uses Ethernet frames, and these PRP Ethernet frames are intended to be compatible with standard LAN switches. The switches simply need to support oversize frames of up to 1528 octets. Most switches will support frame sizes up to 1536 octets, as per ISO/IEC 8802-3<sup>[5]</sup>. PRP places the Redundancy Control Trailer (RCT) into an Ethernet frame just before the Frame Check Sequence (FCS), a location switches do not check, as this is normally considered part of the data payload. The RCT includes a sequence number of the frame, a LAN identifier (for LAN A or LAN B), the size the data in the frame (including the RCT), and a PRP suffix.

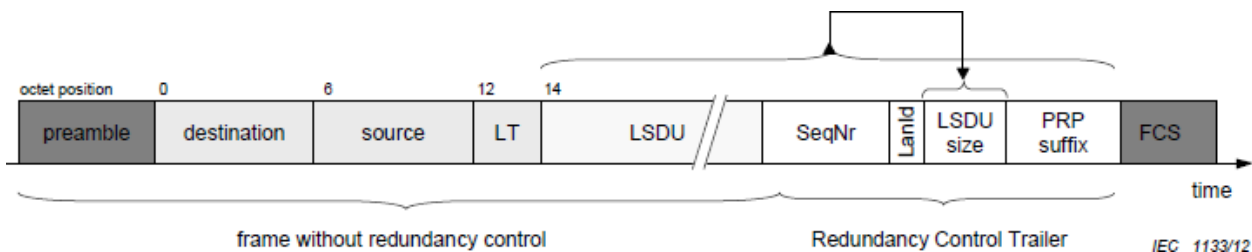

Figure 5: PRP frame<sup>[4]</sup>

The key take away is that the PRP identifier is part of the frame payload, and is ignored by switches. This also does not impact other parts the frame, especially VLAN tagging and identifiers.



The IEC 62439-3 Standard defines some installation rules and guidelines for PRP networks. A short summary of these rules and guidelines is:

- LAN A and LAN B must be separated
- Cables for LAN A and LAN B must be distinctly identified. If colors are used, LAN A should be RED and LAN B should be BLUE.
- Switches for LAN A and LAN B should have distinct identification labels
- The layout of LAN A and LAN B can be different, but shall be fail independent and should have similar timing delays (latencies): this is an important point for PRP. There is no requirement that the two networks be absolutely identical.
- All DANP must be attached to both LAN A and B. DANPs must have the same MAC address on ports A and B, unique in the network. They also must have the same IP address on ports A and B, unique in the network
- All SAN must be attached to only one LAN (A or B), have a unique MAC address in the network, and have a unique IP address in the network.
- Switches on LAN A and LAN B shall be considered to be SANs and have a unique address in the network.

A key advantage of PRP is that the two networks are standard Ethernet networks. All normal network concepts apply, and all normal network tools are available. The most important of these network tools available are the tools used for traffic shaping. With a large network it is critical to have the ability to manage bandwidth across the network. This is especially true for substations using IEC 61850, as GOOSE messages and sampled value messages are multicast messages. Multicast messages propagate across the entire network, even if only a few devices subscribe to a specific multicast message. VLANs are used to limit multicast messages to specific portions of the network, so as not to use bandwidth unnecessarily. MAC address filtering is also sometimes used to manage the flow of specific data, and is also available for use with PRP.

There are many benefits to using PRP for high-availability networks. The first of these is that PRP explicitly achieves “zero” fail over time, due to the use of mirroring frames across both networks. Another advantage is that the PRP networks can use any topology: star networks, ring networks, and any other connection. And these networks are built using standard LAN switches. Traditional devices can still be connected to these networks individually. Most importantly for GOOSE messaging and sampled values, it is still possible for traffic shaping through VLANs, message priority, and MAC address filtering. Note also that these networks may be ring networks, and use RSTP for network recovery inside the individual network. The disadvantages to PRP from a technical aspect are that the two PRP networks must be completely independent: they cannot be connected or bridged together in any way. In a mixed traffic network non-PRP Ethernet traffic could be bridged across the two networks using specific VLAN allocation and filtering, such that PRP tagged frames are not part of the bridging. Careful attention must be paid the field connections, which is why the guidelines

suggest using specific colors for LAN A and LAN B. And obviously, devices that connect to PRP networks must be DANP devices, which require either a specific interface, or connection to the networks through a RedBox.

### 3.2. HSR

HSR uses a different method to provide multiple paths for data. All devices are connected to the network in a ring configuration, as illustrated in Figure 6. A source device publishes identical frames, the "A" frame and the "B" frame, in opposite directions out of the two ports. A destination device receives two identical frames on each port within a certain interval. The device uses the first frame received, and discards the second frame. If a network link fails, only one frame is received, and this frame is used. Even with a large number of nodes on the network, the time difference between the reception of the two frames is negligible, so zero recovery time is achieved. The nodes support the IEEE 802.1D bridge functionality and forward frames from one port to the other, except if the node has already sent the same frame in that same direction. To keep traffic from continually passing around the ring, a node will not forward a frame that this specific node injected into the ring.

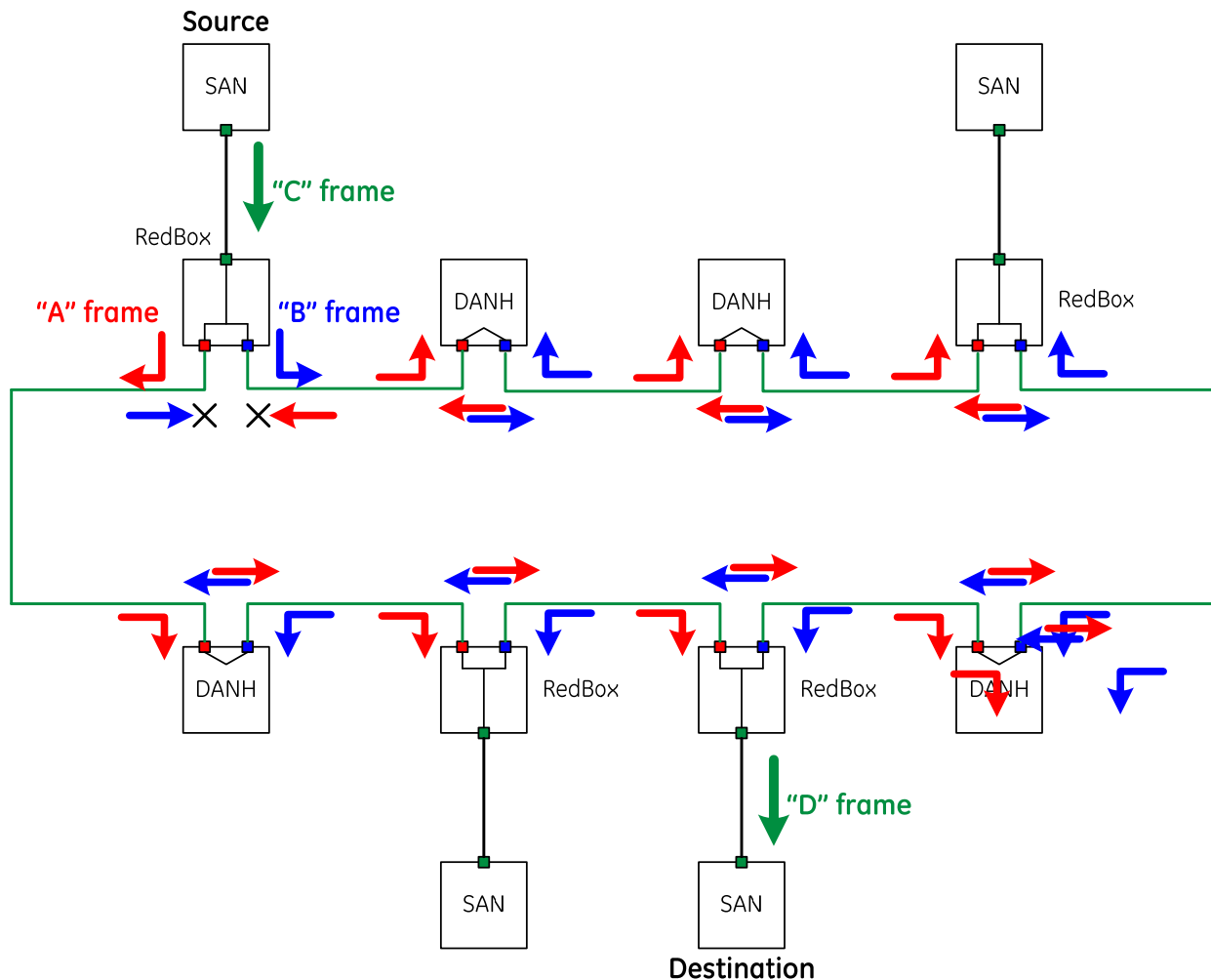

Figure 6: HSR concept

HSR uses similar nodes to PRP. The one difference is that HSR uses a DANH node, as per Figure 7.

- **DANH:** a DANH is a “double attached node implementing HSR”. A DANH has two ports (port A and port B) that have the same abilities.
- **SAN:** single attached nodes are not directly supported in HSR; they must always connect via a RedBox. As LAN switches are considered SANs under IEC 62439-3, LAN switches are not supported in HSR rings.
- **RedBox:** a RedBox device is used to attach SANs to a HSR network. The RedBox acts like a DANH on the HSR side. The RedBox mirrors the “C” frame published by a SAN, and creates the “D” frame from mirrored HSR messages to send to a SAN.
- **VDAN:** Virtual Doubly Attached Node (SAN as visible through a RedBox)
- **QuadBox:** HSR also introduces the concept of a QuadBox, a quadruple port device that connects together two peer HSR rings. The QuadBox behaves as an HSR node in each ring, and is able to filter the traffic between rings and forward traffic from ring to ring.

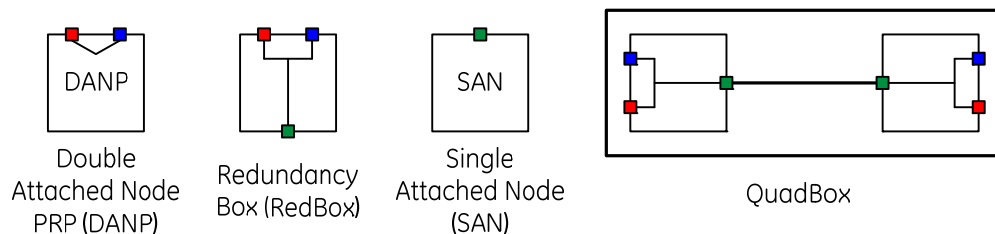
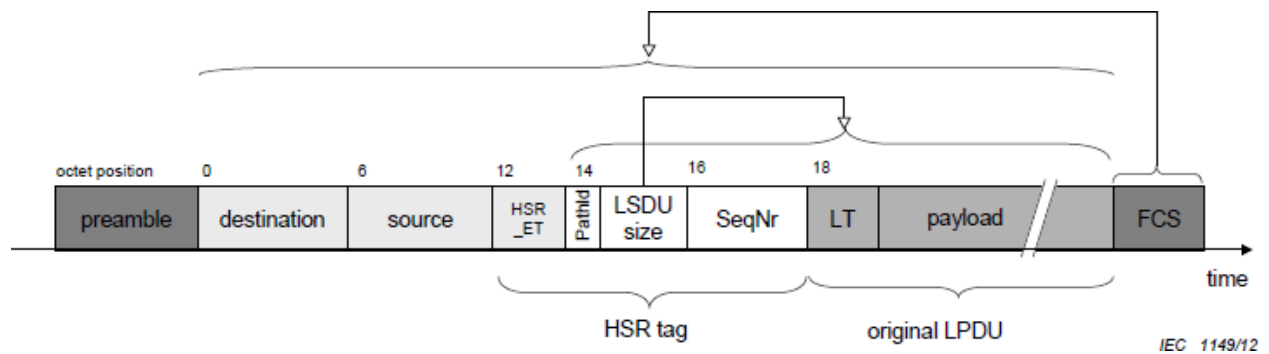

Figure 7: HSR devices

HSR Ethernet frames are not compatible with standard Ethernet frames. HSR frames are identified uniquely by their inserted HSR tag. As illustrated in Figure 8, the HSR tag replaces part of the frame header information: it is not inserted into the payload as with PRP frames. This means the only frames possible on an HSR ring are HSR frames. The HSR tag includes an EtherType HSR identifier, a path identifier, the frame size, and a frame sequence number. The frame sequence number, combined with the source address in the frame, is used to identify duplicate frames. A DANH node shall always accept frames that it has not received before, and shall not forward duplicate frames.



### Figure 8: HSR frame<sup>[4]</sup>

The IEC 62439-3 Standard defines some installation rules and guidelines for HSR networks. A short summary of these rules and guidelines is:

- All nodes in the ring must be DANH nodes.
- Non-HSR devices can only be connected to an HSR ring using a RedBox or a QuadBox.
- LAN switches cannot be inserted in the ring. LAN switches are a SAN device.
- Cables for Port A and Port B should be distinctly identified

HSR does not require VLANs and priorities for operation; however HSR does support both VLANs and priority. HSR nodes are expected to support at least two levels of priority according to IEEE 802.1D. An HSR node is also expected to filter VLAN traffic according to IEEE 802.1q, and to filter multicast traffic.

While HSR nodes do support VLAN traffic, it is not practical to do traffic shaping using VLANs on an HSR ring. Every source data frame is published in both directions around the ring. For HSR to provide high availability, both unicast frames must travel completely around the ring to destination devices. In case of multicast (GOOSE) frames, both frames must travel completely around the ring until reaching the originator devices (i.e. the “whole ring”). Therefore, any VLAN will have to include every node on the ring. This means that on an individual HSR ring, no traffic shaping is possible except when applied to C or D frames which are outside of the HSR ring per se. Because no traffic shaping is possible inside the ring, the number of nodes connected to an HSR rings is limited by the node port that has the least bandwidth. In current devices, this means bandwidth is limited to 100 Mb. For station bus, this limits HSR rings to around 20 devices, and for process bus this limit is around 6 devices, if these devices publish sampled values.

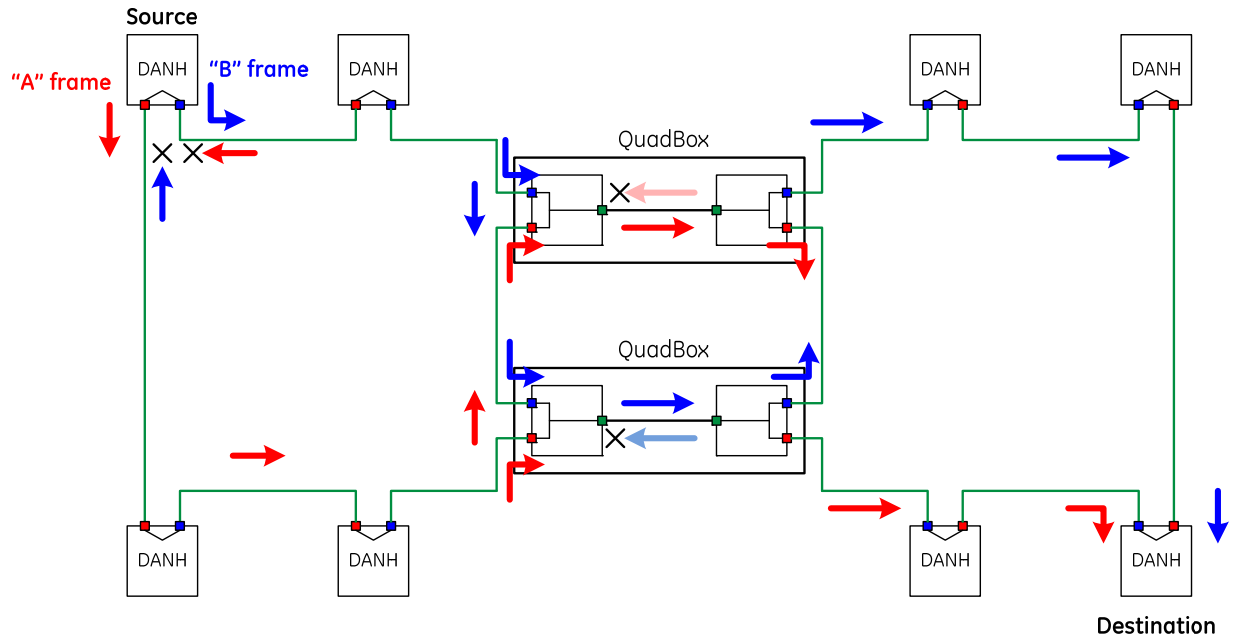

Figure 9: QuadBox and HSR rings

Traffic shaping when using HSR therefore takes another form, which is based on using meshed networks to create physical separation of HSR rings. The first method is to use a pair of QuadBoxes to tie peer HSR rings together. The HSR rings can be defined in any number of ways such as physical location of the node devices, or by bandwidth requirements, or by operating requirements. HSR frames circulate around their original ring. The QuadBoxes are used to filter and pass traffic between the rings as appropriate. Figure 9 illustrates the general concept. One QuadBox is adequate to tie peer HSR rings together. Two QuadBoxes are used to maintain availability in case of the failure of one QuadBox.

A second way to use physical connections to do traffic shaping is to tie an HSR ring to PRP networks, as in Figure 10. The HSR ring includes two RedBoxes. The single port of the RedBox is connected to one of the PRP LANs. The single port of the second RedBox is connected to the other PRP LAN. In this manner, a source connected to the PRP networks can publish frames to destinations in the HSR ring and still support zero recovery time. And sources in the HSR ring can publish frames to destinations on the PRP network and still support zero recovery time. So traffic shaping occurs by limiting the size of the HSR ring, and by using standard traffic shaping techniques on the PRP LANs.

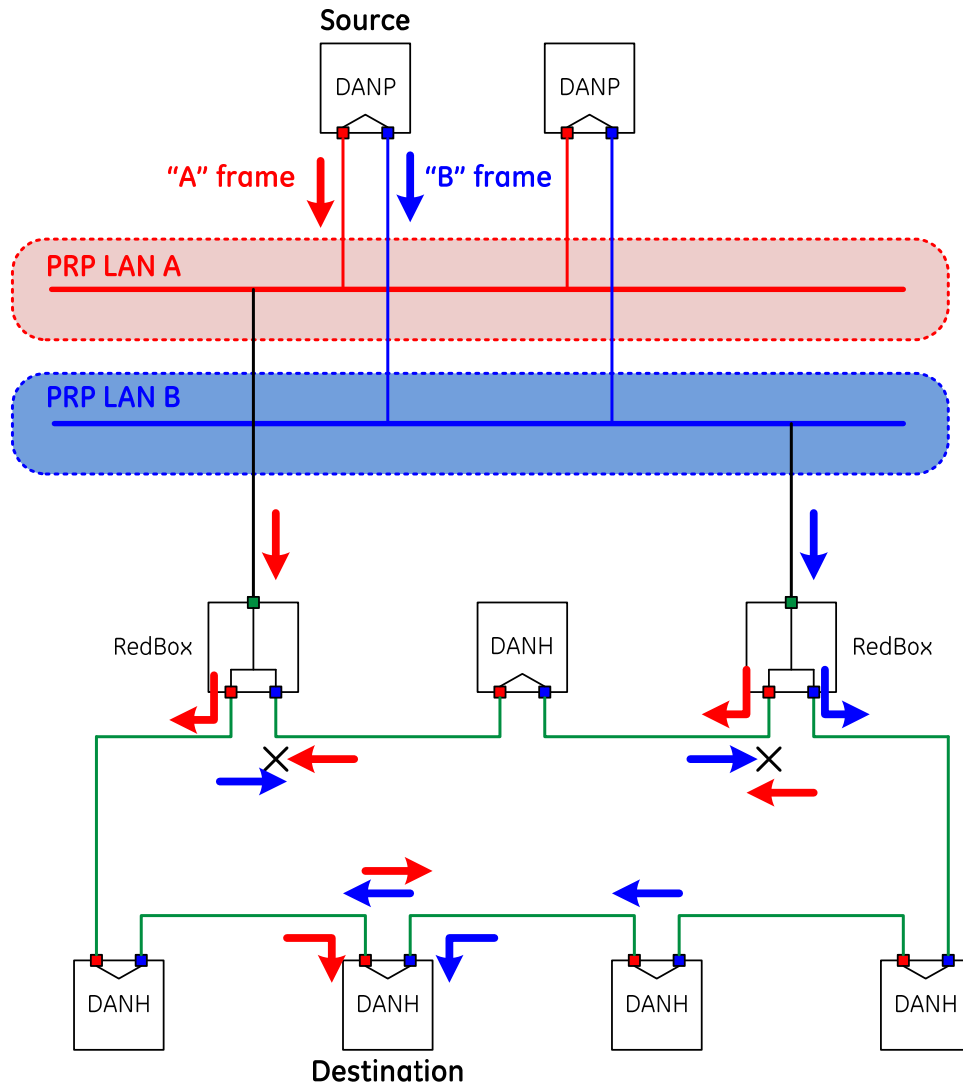

Figure 10: HSR rings and PRP networks

There are benefits when using HSR for high-availability networks. The biggest of these is in simplicity: no Ethernet switches are used, so there is no need for network management and network configuration. Simply connect HSR compliant devices together in a ring and configure the communications parameters in these devices. This should also result in a benefit in regards to capital cost, as there may be no need for dedicated communications devices, depending on the end devices used, the application, and the network architecture. The disadvantages are that HSR only makes sense when all devices can be turned off at the same time (e.g. industrial printing press, canning factory, auto assembly line), by shutting down the whole "line". However, in substations it is rarely possible to shut down all the devices on the ring during maintenance testing. The other major disadvantage HSR is that of bandwidth. Because traffic shaping is not possible on the HSR ring itself, the number of devices connected on an HSR ring is limited. Segmenting HSR rings through physical connections to perform traffic shaping goes against the simplicity that is the major benefit of HSR.

### 3.3. Comparison of PRP to HSR

Both PRP and HSR can be applied as a solution to provide a high-availability network. It is useful to understand the benefits of each, and the strengths of each, when selecting which method to use for a specific network or application.

PRP is a redundancy protocol operating through standard Ethernet frames, without requiring special hardware. Various topologies of networks can be deployed on LAN A and B, using standard Ethernet switches. These are standard networks, so RSTP may be used within LAN A and LAN B to provide an additional level of availability. The use of RSTP does not affect PRP performance. Once again, since these are standard networks, they can easily implement traffic shaping for GOOSE management. And any regular device or node can be connected to one of the networks as a SAN, and still operate correctly.

HSR is a redundancy protocol that uses specialized Ethernet frames, and requires specialized LAN nodes. However, these nodes can operate in HSR mode or PRP mode with the same hardware. Because HSR frames must travel completely around the ring in both directions, traffic shaping cannot be implemented unless using an HSR mesh topology, which adds cost and complexity. All devices on the ring must be HSR devices so connecting a SAN requires a RedBox.

#### 3.3.1. Availability

PRP networks provide essentially 4 paths for a message to travel to a device: the message can travel either direction on each network. So PRP handles  $n+1$  contingencies easily. HSR provides only 2 paths for a message to travel: each direction around the ring. This increases the likelihood of  $n+1$  contingencies having an undesirable impact. HSR is, at heart, a ring without switches. Once a device is out of service (say for testing), or a transceiver fails, the ring is no longer a ring, and a  $n+1$  contingency becomes a real concern.

#### 3.3.2. Testing

With PRP, isolation for testing is clear because the other network exists. Shutting down one device, or a couple of devices, does not impact communications between all the active devices on the networks. With HSR, device maintenance is difficult. Isolating a device breaks the ring. If 2 devices are isolated, as is sometimes necessary during test procedure, then depending on where these devices are in the ring, communications to some devices may be completely interrupted.

#### 3.3.3. HSR: considerations for operations

Normally, in substations, when a permit to work (PTW) is opened to work in an area of the substation, that specific area must become isolated and powered off. By powering off the IED(s), HSR is broken, and the ring is operating in an  $n+1$  contingency mode, where any other additional failure will bring down the communications network (Note: at the time of writing this paper, the authors had no knowledge of an HSR implementation that would continue to function passively and forward A and B frames when the power supply of the respective IED is turned off). If more than one IED is part of the PTW, and the IEDs are not adjacent in the HSR (e.g. bays away from each other) – then the IED(s) “in the middle” will be left without communications. However, these IEDs are not part of the PTW, and must continue to operate. Therefore, the PTW must now contain instructions to re-wire the HSR communications around the bays/IEDs under the PTW. This is a problem, because the operations

department will be likely not approve the inclusion in the PTW of devices that are not meant to be interrupted (imagine critical availability bays).

Making up the temporary network wiring is another problem. This wiring must be designed specifically for the installation, and installed in such a way without causing EHS hazards. This involves an actual design and installation process. This also requires field personnel qualified in handling communications cabling, especially fiber-optic cables. This is normally a different workforce than the one doing the testing of equipment. The skilled technicians must be on-site at the beginning of the maintenance process, to reconfigure the system for testing; and at the end of the process, to restore the system to normal. Also, changing the communications network either for testing or after testing requires at least a minimal verification that the system is communicating correctly. Also note that while patching cables, communications to certain IEDs will likely be briefly interrupted. This carries some risk of not correctly responding to an event that may happen coincidentally during the PTW.

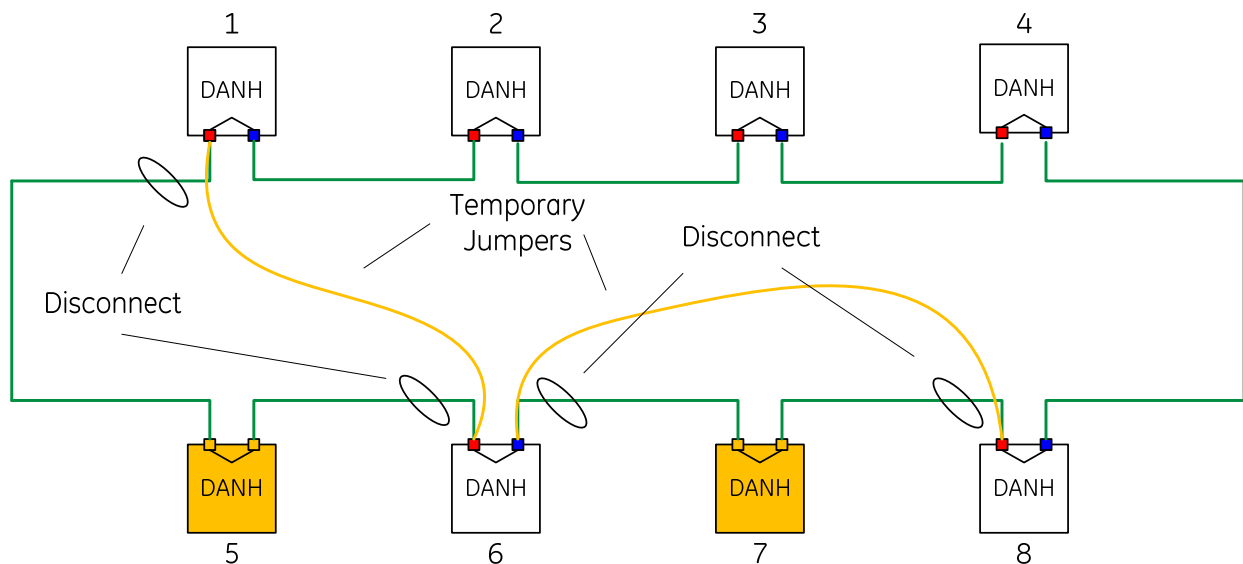

**Figure 11: HSR reconfiguration for testing**

Consider the simple example of Figure 11. Nodes 5 and 7 will be shut down as part of the PTW. Node 6 is to remain in service. To keep Node 6 in service, it is necessary to disconnect 4 cables and connect 2 new jumper cables. All of this must be done in a specific order. These steps need to be reversed when the testing or maintenance work is complete. The work instructions complicate further if the two PTW devices need to be connected together for maintenance and test while under PTW (but not to the other ones) – for e.g. test GOOSE between PTW nodes 5 and 7 (these temporary connections are not depicted above). The statement of work and work procedures for even this simple scenario will be very involved and time consuming to create and to follow.

### 3.3.4. Cost of ownership

A major criterion for choosing between PRP and HSR is cost of ownership. This cost of ownership must include both capital costs, and operating and maintenance costs.



In terms of capital costs, PRP requires two networks, and all the switches that make up both of those networks. PRP also requires the cost of designing, configuring, installing, and commissioning these two communication networks. There is also some cost involved in terms of panel space to mount the switches and the control house. In some applications, such as process bus, cabling costs should also be considered, as the distance between primary equipment and the control house can sometimes be 500 meters or more. Note that in any application where a high-availability network is being considered, the original design probably called for installing redundant networks, so most of these cost have already been accounted for.

HSR has the perceived capital cost advantage of not requiring Ethernet switches. The only costs are the HSR capable devices and communications cabling. Once again, when using HSR for process bus there will be some long cables coming across the switchyard, but the number of cables is reduced because there is only a cable for each end of the ring, and not each individual device. However, the capital cost advantage of HSR goes away as the size of the network increases. Large networks, or devices that consume large amounts of bandwidth, require HSR rings tied together with mesh networks in some manner. This means that HSR rings require either RedBoxes or QuadBoxes to form the mesh networks. These devices cost the same as Ethernet switches, and using mesh networks requires the cost of network design, configuration, installation, and commissioning. Also note that testing HSR networks may significantly increase in operating expenses due to the potential need to re-cable the network during maintenance testing.

A simple case study can help compare PRP to HSR from the perspective of total cost of ownership (capital expenses and operating expenses) versus capital expense savings alone. Imagine a row of 10x GIS breakers, with 20 IEDs (2 in each bay), and 2 communications gateways.

PRP could use 2 switches on each LAN, so 4 four switches in all, plus design, configuration, installation, and commissioning of the network. HSR will start by connecting all 22 devices in a ring, so no additional capital costs, theoretically. However, 22 devices is close to the upper limit for the number of devices that can be successfully applied on a 100 Mb HSR ring. Therefore, from a reliability and performance standpoint, it is desirable to split this into two HSR rings tied together in a meshed network. This requires the installation of 2 QuadBoxes, and the design, configuration, installation, and commissioning of these QuadBoxes. So for a substation of the size, there is no particular capital cost benefit to either PRP or HSR.

Another capital expense to consider is that of commissioning. Not just commissioning the network, but commissioning a new substation or a new protection and control system. PRP obviously requires specialized technicians on-site to commission the backbone communications network. However, individual end devices can be connected, disconnected, powered up, or shut down depending on the needs of commissioning without requiring communications technicians. An HSR network requires communications resources on site that need to constantly change and patch the fiber optics as IEDs are being brought up. Typically these are not the same personnel who perform the commissioning/SAT tests, so communications technicians need to be on-site during the entire commissioning process, basically adding the cost of additional skilled resources to the project.

Operating expenses are the other part of the total cost of ownership. The operating expenses of PRP are going to be simply that of device management. Ethernet switches are an IED that needs to be managed, updated, monitor for failure, and eventually replaced. During maintenance activities in the substation, there are no special costs added by using PRP. Individual devices, or combinations of devices, can be shut down or repowered without impacting any in-service device. So there is no need for specialized personnel support communications requirements. And there is no special risk introduced through testing. HSR does potentially introduce additional operating expenses. In any situation, which is likely to be true for large substations, where jumper cables must be installed to patch in-service devices across a break in the ring caused by testing activities, operating expenses will be higher than that of PRP. In addition to the normal maintenance personnel, communications technicians will need to be on-site to remove in-service cables, makeup and install jumper cables, verify the network performance, and then to reverse this process once maintenance testing is complete. These patch cables may also require some engineering design time before maintenance testing begins, which is an additional cost. Note also that installing jumper cables in this manner carries some risk: devices protecting in-service equipment may not be communicating for a short time while jumper cables are being installed, there is a risk of the jumper cables not being installed correctly causing breaks in the network. So installing jumper cables also forces more testing, to verify the network is working correctly after the jumper cables are installed.

It is likely the additional human labor involved only at commissioning and site acceptance testing stage in an HSR topology will equate to a higher cost than PRP switches. Consider that in North America the cost of one additional skilled resource, including T&L expenses is approximately \$1000 a day. Versus an Ethernet switch that carries the capital cost of proximately \$5000. And any maintenance testing activity has the potential to add \$1000 per day in cost.

Table 2 is a short estimate of the total cost of ownership for the 10x GIS breaker transmission substation over a 10 year period. This is simple data, based on present value. The table shows the material costs of Ethernet switches, QuadBoxes, and the labor to design, install, and commission the network. (Labor rates in this table are \$100 per hour). "Station Commissioning Labor" is the time network technicians must spend on site to support substation and protection and control technicians while the station is being commissioned, also at \$100 per hour. These are all capital costs. "Device Maintenance" is the cost to maintain network devices over a 10 year period; shown at \$1000 per day to include T&L and other cost loadings. "Testing Callouts" is the cost to reconfigure the network for substation maintenance activities as required by the Permit To Work, and are also shown at \$1000 per day to include T&L and other cost loadings. Device Maintenance and Maintenance Callouts are operating and maintenance expenses.

Table 2: Total cost of ownership over 10 years

	PRP	HSR	HSR / Maintenance	HSR w/ QuadBox	HSR w/ QuadBox, Maint
Switches	\$20,000	\$0	\$0	\$0	\$0
QuadBoxes	\$0	\$0	\$0	\$10,000	\$10,000
Panels	\$10,000	\$0	\$0	\$10,000	\$10,000
Labor	\$12,800	\$6,600	\$6,600	\$13,000	\$13,000
Station Commissioning Labor	\$0	\$16,000	\$16,000	\$16,000	\$16,000
Device Maintenance	\$2,000	\$0	\$0	\$0	\$0
Testing Callouts	\$0	\$0	\$20,000	\$0	\$20,000
<b>CapEx</b>	<b>\$42,800</b>	<b>\$22,600</b>	<b>\$22,600</b>	<b>\$49,000</b>	<b>\$49,000</b>
<b>OpEx</b>	<b>\$2,000</b>	<b>\$0</b>	<b>\$20,000</b>	<b>\$0</b>	<b>\$20,000</b>
<b>Total</b>	<b>\$44,800</b>	<b>\$22,600</b>	<b>\$42,600</b>	<b>\$49,000</b>	<b>\$69,000</b>

PRP will require 4 Ethernet switches, 2 panels to mount the switches, and the resulting labor. No Station Commissioning Labor is required, as substation and protection and control personnel can shut down individual devices are required. The assumption with PRP is that 1 switch will require 2 days of maintenance during a 10 year period. Testing callouts are not required, because shutting down a device does not impact the rest of the network. The baseline cost for PRP over 10 years is then \$45,000 dollars

HSR is apparently less expensive, with a cost of \$23,000. Most of this labor is time on site by network technicians to support substation commissioning. However, assuming there is a need for one testing callout per year, with 2 days per callout (to reconfigure, and then restore the network); the cost for HSR quickly becomes comparable to PRP. Also, a single HSR ring is not ideal for a network of 22 devices, so the system should be broken into 2 HSR rings, using QuadBoxes mounted in panels. This quickly increases the cost of the system to more than PRP for a complex network. Obviously, actual costs for this work can vary greatly with the cost of materials and labors, and the estimate for the

amount of labor required. The point is that part the criterion for selecting PRP and HSR is to perform a total cost of ownership exercise, looking at both upfront capital costs and long term operating and maintenance costs.

### **3.3.5. Selecting PRP or HSR**

The general criterion then, for choosing PRP or HSR for a high-availability network, is going to be size and complexity of the network. For small, simple, and/or low cost distribution substations and industrial power systems, HSR can be a good choice. Low capital costs and simplicity of the network are big advantages in this situation. However, this advantage to HSR is only true if the testing requirements for substation equipment don't add significant operating costs. Meaning if the ring can be broken by taking down only one device, or the entire substation can be taken down for maintenance in one shot, then HSR is fully appropriate. In other words, HSR should be used when it is fit for purpose for the application.

PRP is a better fit in transmission or complex distribution substations, where the size of the system is liable to be large, or where strong permit to work regulatory needs exist. For the vast majority of applications, then, PRP is going to be a better choice from both of performance and from a cost perspective.

The important choice is to do a total cost of ownership analysis, including both capital expenditures and the yearly rates return of operating expenditures to help drive the choice.

## **4. Considerations for adopting high availability networks**

A first consideration for applying a PRP or HSR high-availability network is whether such a network is truly needed for the application. In many applications, a traditional LAN using traditional availability methods such as RSTP will be more than adequate. Using a traditional LAN with RSTP will control cost and complexity for these applications. So the choice depends on the needs of the application.

### **4.1. Traditional SCADA**

Traditional SCADA can be defined as simply the need for reporting of power system data and equipment status, along with manual control of equipment by SCADA operators. In an IEC 61850 context, traditional SCADA means both buffered and unbuffered reporting, along with MMS control services. In this type of application, a simple ring network using RSTP is more than adequate. The data and controls coming over the network are not especially mission-critical. Any time delay introduced during a reconfiguration of a RSTP network will have no special impact on the power system. In fact, the intent of buffered reporting in IEC 61850 is to overcome this type of network configuration.

### **4.2. SCADA with automation**

In many substations, traditional SCADA works conjointly with automation needs, such as interlocking, automatic switching sequences, and the like. In this type of application, a simple ring network using RSTP may not be sufficient. Any time delay introduced by a network reconfiguration may undesirably impact and automation sequence. Before the development of PRP and HSR, the best practice for reliability was to use dual redundant LANs. Dual LANs ensure messages are always received, but this

takes explicit configuration at the receiving devices to accept and process the redundant messages. The high-availability networks defined in IEC 62439-3 have been developed explicitly for this type of situation. This is specifically true of PRP. If dual LANs are proposed or in use, there is no additional cost to apply PRP, as PRP uses redundant networks. The only requirement is that devices support PRP, which may require the use of a RedBox to integrate legacy devices. Applying an HSR network is also possible, depending on the size and needs of the application.

### **4.3. SCADA with GOOSE messaging**

The use of IEC 61850 in substations often combines the traditional SCADA requirements of reporting and control along with protection signaling for blocking, unblocking, and permissive signals. This protection signaling will use GOOSE messaging, which can be published over the same SCADA network. As these GOOSE messages are mission-critical, a simple ring with RSTP is not sufficient. Dual redundant LANs require redundant GOOSE messages carrying the same data, which is not an ideal situation. The solution is to use one of the high-availability networks of IEC 62439-3. Either PRP or HSR is sufficient depending on the application requirements. Legacy devices will require the use of a RedBox.

### **4.4. Process bus**

Process bus is simply distributed I/O for protection and control systems. This becomes a direct communications interface between primary equipment and protective relays, including analog measurements published as sampled values, and GOOSE messaging for status and control. Therefore, all this data is mission-critical. Once again, a simple ring network, or dual redundant networks are not sufficient. Either PRP or HSR is required for the real-world application of process bus.

## **5. Examples of applying PRP and HSR**

The best way to look at applying PRP and HSR is to use some simple case studies. The assumption and all of these case studies is that mission-critical data is being published across the network, and therefore a high-availability network is required. These case studies explore both station bus applications, and process bus applications. In all these discussions, it is assumed that devices are PRP or HSR capable as required, and there is no difference in cost between a PRP version of the device and an HSR version of the device. Legacy devices will require a RedBox, but this is true for both PRP and HSR, so the costs are the same.

### **5.1. Small distribution substation**

This specific example is a small distribution substation, as shown in Figure 12: one incoming feeder, a transformer, and four outgoing feeders, typical of distribution substations in North America. However, the same thought processes around using PRP or HSR apply for any small substation or installation.

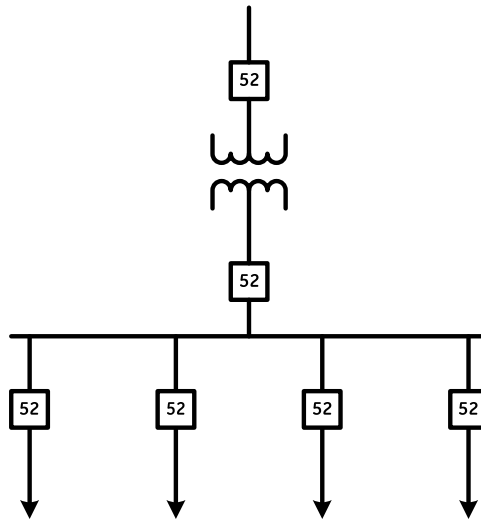

Figure 12: Small distribution substation

For purposes of this example, the protection is assumed to be transformer protection relay, a bus protection relay, and individual feeder protection relays. The substation also has a communications gateway, for seven IEDs. These devices need to communicate with each other to provide functions like traditional SCADA (reporting and control) through MMS services, and GOOSE messaging for zone sequence interlock protection, and breaker failure initiate signals, along with equipment status signals.

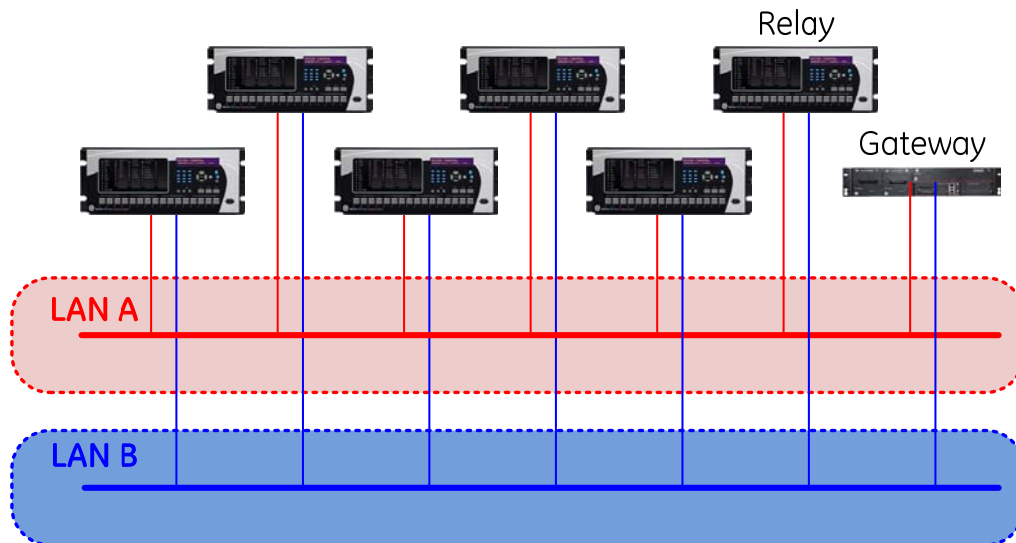

Figure 13: PRP networks for small distribution substation

To apply PRP, a typical communications arrangement may look something like Figure 13. All devices are connected to both LAN A and LAN B. The LANs, in this instance, can consist of an individual switch, because so few ports are needed. The HSR network of Figure 14 eliminates the switches.

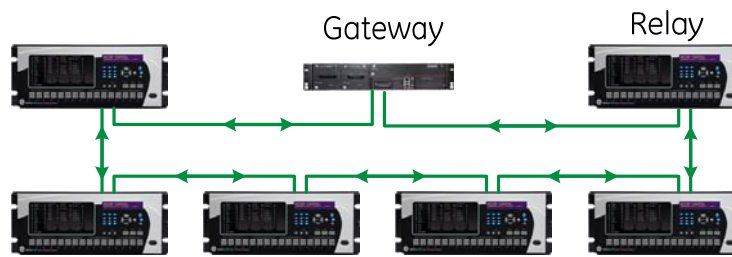

Figure 14: HSR network for small distribution substation

### 5.1.1. PRP for a small distribution substation

PRP for this type of substation will require only two Ethernet switches, one to establish each LAN. This also requires one or two panels to mount the switches, along with network design, installation, and commissioning. There will be no need to perform any traffic shaping in a network this small, as bandwidth is not a concern.

### 5.1.2. HSR for a small distribution substation

HSR for this small distribution substation requires only cabling between the IEDs, and is very simple to design and install. The concerns with practical applications of HSR are always around bandwidth / traffic shaping, and the potential costs of testing. For a network this small, traffic shaping is not an issue.

In regards to equipment testing, it is likely that the entire substation can be shut down during Permit To Work situations. Even if the substation is to remain in service during a PTW scenario, it is likely only one IED will be shut down at a time. Even under this n+1 contingency, the only real operating risk is an undesirable bus trip. The only mission critical signals are zone sequence interlocking block signals and breaker failure initiate signals. A bus trip due to communications failure, or a backup protection operation due to communications failure, is a reasonable risk to accept. So it is likely there will be no special system reconfiguration needed during equipment testing.

### 5.1.3. Appropriate network type for small distribution substations

HSR is the appropriate network for a small distribution substation. Capital cost clearly favors HSR over PRP. No Ethernet switches, no switch panels, no network design are required. Simplicity also favors HSR over PRP for the same reason: a small number of closely located devices communicating to each other. It is more likely many utilities will star-connect all devices together through a single switch rather than install PRP due to the simplicity of configuration. So it is unlikely to use PRP for such a small system. Operating and maintenance costs for PRP and HSR are relatively equal. As described, there is little risk to communications failure, even with one IED shut down for equipment testing.

## 5.2. Transmission substation

It is more likely to apply high reliability networks in larger substations, especially transmission substations. Consider a breaker-and-a-half transmission substation similar to that of Figure 15. Every zone of protection (6 lines, 2 transformers, and 2 buses) will have redundant relays. For

communications purposes, there will also be 2 communications gateways. This is 22 IEDs for this substation. These devices need to communicate with each other to provide functions like traditional SCADA (reporting and control) through MMS services, and GOOSE messaging for blocking signals and for breaker failure initiate signals, along with equipment status signals. GOOSE and MMS for automation purposes may also be in use.

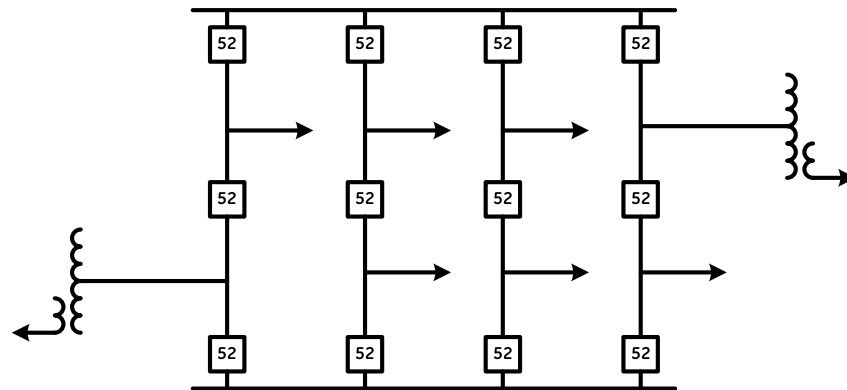

Figure 15: Transmission substation

A typical PRP arrangement for this substation will look something like Figure 16. All devices are connected to both LAN A and LAN B. The LANs require multiple switches, due to the number of devices on the network. The HSR network of Figure 17 ties all the devices in one single ring. For both PRP and HSR, there are other permutations of these networks possible. For these simple case studies, only these basic configurations are discussed.

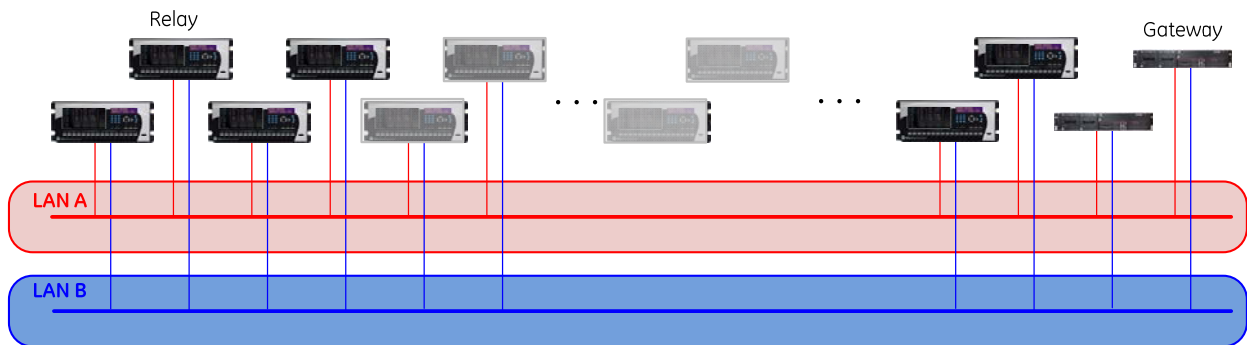

Figure 16: PRP networks for transmission substation





Figure 17: HSR network for transmission substation

### 5.2.1. PRP for a transmission substation

The PRP networks for this substation will require 2 or 3 Ethernet switches. It is desirable to perform traffic shaping through VLANs to limit the propagation of GOOSE messages through the network and to manage bandwidth. So each network requires 2 or 3 switches, a panel to mount the switches, and network design, installation, and commissioning time. The network backbone bandwidth requirements are only limited by the capabilities of the switches. 1 Gb bandwidth is possible today, supporting very large networks. Upgrading the capacity to 10 Gb means simply upgrading the Ethernet switches, without changing applications or network configuration.

### 5.2.2. HSR for a transmission substation

Theoretically, HSR can use a single HSR ring for this substation. The longest distance a message has to travel is 21 hops, which introduces some time delay between the “A” frame and the “B” frame, but this delay should not be significant. A drawback is that traffic shaping and traffic management is not possible on HSR networks. All GOOSE messages will propagate both directions around the HSR ring. This effectively limits the number of devices that can be connected on HSR ring due to bandwidth considerations. The appropriate solution to this is to break the network into separate HSR rings, connected by QuadBoxes, as in Figure 18. This increases the capital cost of applying HSR, as QuadBoxes, panels to mount the QuadBoxes, and design, installation, and commissioning labor are required. Increasing the bandwidth to support more data and more devices requires upgrading all the devices.

Equipment testing during PTW situations will potentially add significant operating costs. There are many test scenarios that will require reconfiguration of the HSR ring to bypass IEDs that have been de-energized.

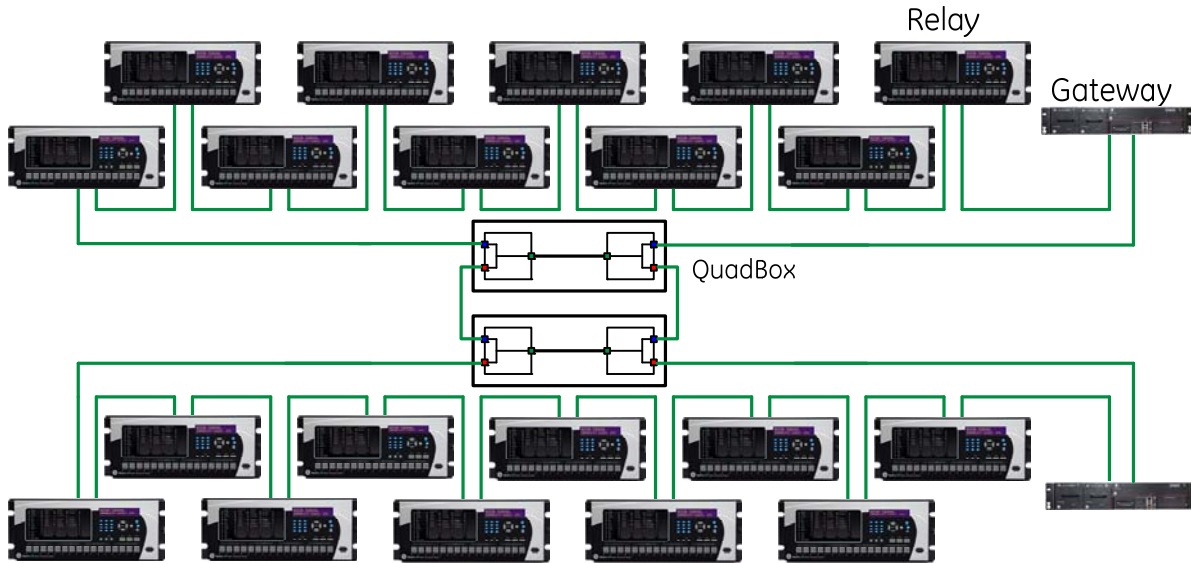

Figure 18: Segmented HSR networks for transmission substation

### 5.2.3. Appropriate network type for a transmission substation

A PRP network is the best choice for a high availability network for transmission substations. Capital costs for PRP and HSR are going to be similar, as both will require communications devices (switches or QuadBoxes), and the resulting network installation costs. PRP will be the simpler solution: installing two identical networks, while supporting traffic shaping using well known techniques, as opposed to the meshed HSR networks required by a large installation. PRP networks can also support greater bandwidth, with a simple upgrade path to increase bandwidth. The maintenance costs associated with equipment testing under HSR will be determined by the specifics of a PTW, but will tend to be much greater than that of HSR.

### 5.3. Process bus on a breaker-and-a-half arrangement

One situation where the use of high reliability networks is critical is in process bus, or distributed I/O for protection and control. The example of Figure 19 considers two breaker-and-a-half line terminals. Every measurement point uses two process interface units (PIUs) to sample analog values and interface to status and control points on the primary equipment. As this is a transmission substation, the two lines will use redundant relays for protection. This results in 10 PIUs and 4 relays. Essentially all signals on process bus are mission-critical. Sampled value messages are necessary for protection algorithms to work, and control messages sent by GOOSE messages are used for tripping breakers, and are critical for fault conditions.

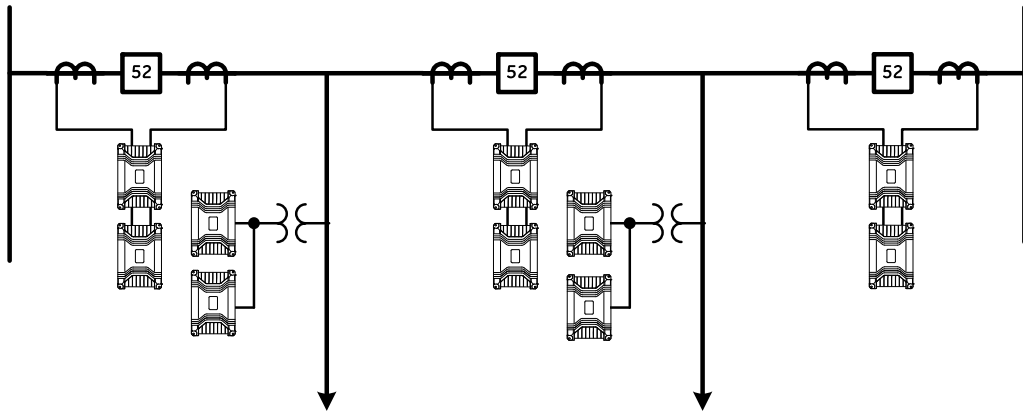

**Figure 19: Breaker-and-a-half terminals with process interface units**

A PRP arrangement for this process bus network will look like Figure 20. All devices are connected to both LAN A and LAN B. The LANs require multiple switches, due to the number of devices on the network. Note that the switches for this process bus network will most likely be mounted in the control house. This means all cabling from the PIUs must be pulled from the PIU location in the switchyard to the appropriate Ethernet switches in the control house.

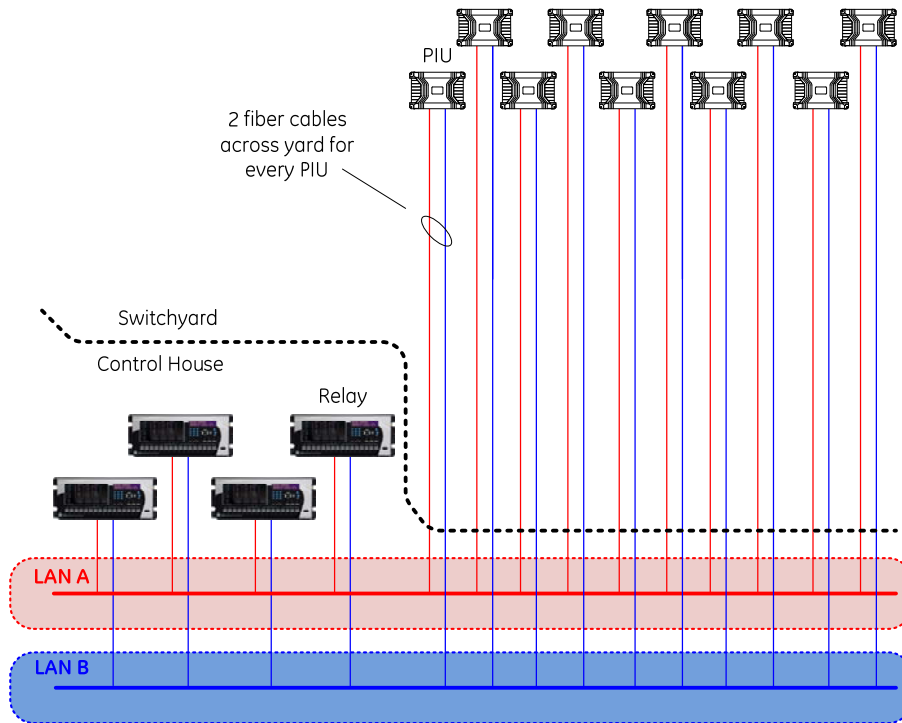

**Figure 20: PRP networks for breaker-and-a-half process bus**

The HSR network of Figure 21 ties all the devices in one single ring. With HSR, only two fiber-optic cables actually go across the switchyard. These are the cables from the PIU on each end of the ring. However, with HSR, it is necessary to install fiber cables between PIUs in the switchyard.

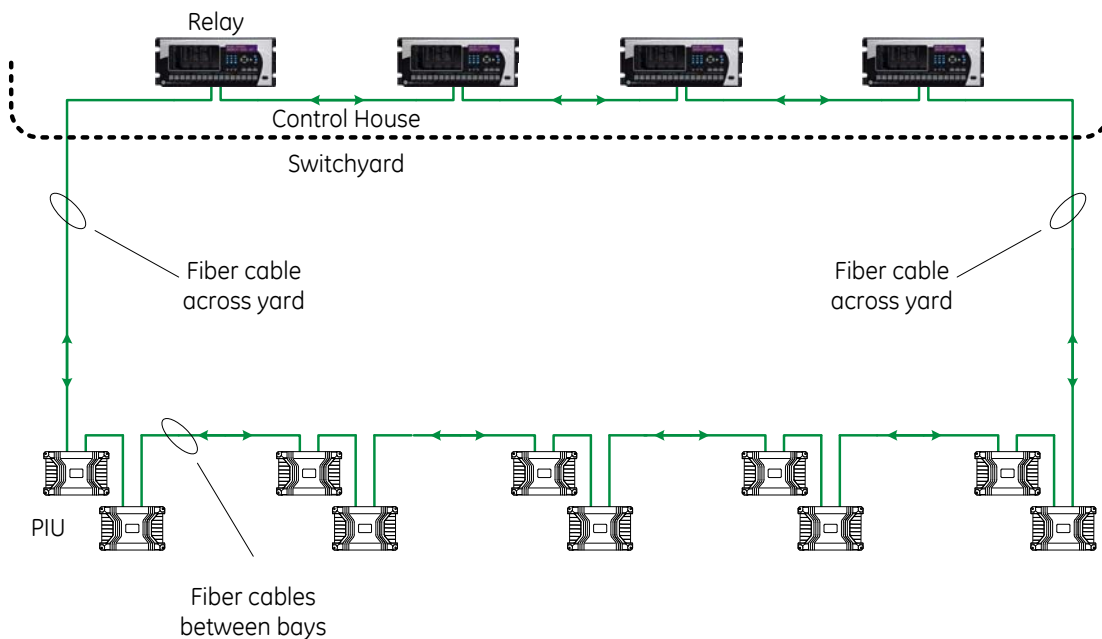

HSR network for breaker-and-a-half process bus

Figure 21:

### 5.3.1. PRP for process bus on a breaker-and-a-half arrangement

The capital cost with PRP is going to be the capital cost of the network. This example looks only at a portion of the total substation, and the LANs will be much larger to accommodate the entire substation. Another cost is the cabling from I/O devices to the LANs. Outdoor fiber cable is expensive (\$10 to \$20 per meter), and requires significant labor cost for installation. Traffic shaping to manage bandwidth is critical for process bus, and is easily accomplished using VLANs. Ethernet switches can be mounted in the switchyard to reduce cabling costs, but this leads to equipment reliability issues. It is more likely that Ethernet switches will be mounted in the control house.

### 5.3.2. HSR for process bus on a breaker-and-a-half arrangement

The capital cost for HSR depends on the number of devices to connect, and the bandwidth required. Figure 21 shows a single HSR ring to connect process interface units and relays together for these two line bays. However, the PIUs require 5.5 Mb of bandwidth each, which is basically close to the operational limit of a 100 Mb ring, once you consider GOOSE traffic. Therefore, two HSR rings may be a better design, simply for the PIUs. Expanding to add more PIUs will absolutely require multiple HSR rings. Another cost is that of cabling: fiber optic cables must be installed between devices in the switchyard. Routing this cable can be complicated, and may require installing new cable trench between primary equipment. Testing may add significant operating costs, depending on the requirements of PTWs in regards to equipment outages.

### 5.3.3. Appropriate network type for process bus on breaker-and-a-half arrangement

PRP is the appropriate high availability network for process bus on breaker-and-a-half arrangements. The capital costs between PRP and HSR networks will be similar. PRP is more appropriate due to simplicity: multiple devices and zones can be connected to the PRP networks,

bandwidth is managed with standard traffic shaping through VLANs, and bandwidth can be increased by upgrading only the switches. Cabling is also simpler: even though cables are required from each I/O device, they will use the same cable trench as other field wiring. Operating costs should also be less with PRP, as no special accommodations must be made to meet the requirements of a PTW.

### 5.4. Process bus in a line bay

A common arrangement for substations is to use the bay concept. The example of Figure 22 shows a double bus single breaker line bay with process bus equipment. Process interface units or merging units are used to acquire analog measurements. Remote I/O modules (RIOs) are used for status and control points. Redundant merging units will be used for critical analog measurements, redundant RIOs will be used for the circuit breaker, and only an individual RIO for every other noncritical control point. This line bay will therefore have 10 I/O devices in its process bus network. Relaying for this line bay once again uses redundant relays. Since this is process bus, essentially all signals are mission-critical.

A PRP arrangement for this process bus network will look like Figure 23. All devices are connected to both LAN A and LAN B. The LANs require multiple switches, due to the number of devices on the network. As with the breaker-and-a-half process bus arrangements, the switches will most likely be mounted in the control house. This means all of the I/O devices require cabling across the switchyard to the appropriate Ethernet switches in the control house.

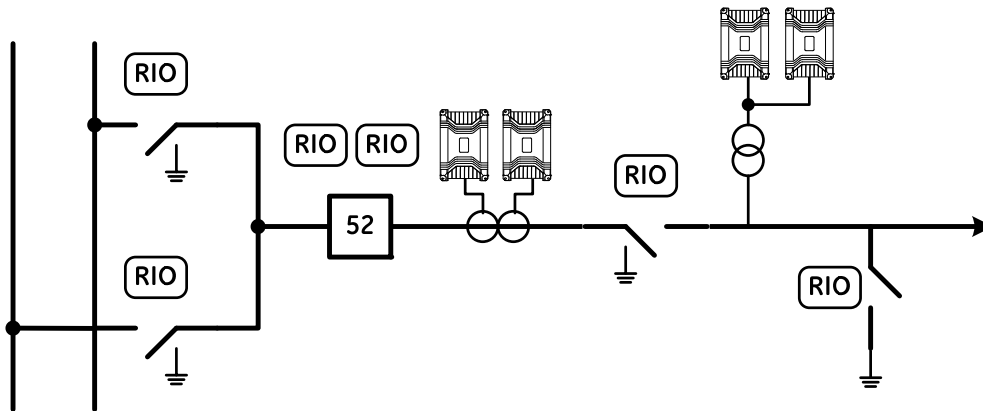

Figure 22: Line bay with process bus

#### The HSR network of

Figure 24 ties all the devices in one single ring. With HSR, only two fiber-optic cables actually go across the switchyard. These are the cables from the I/O device on each end of the ring. However, once again, it is necessary to install fiber cables between I/O devices in the switchyard.

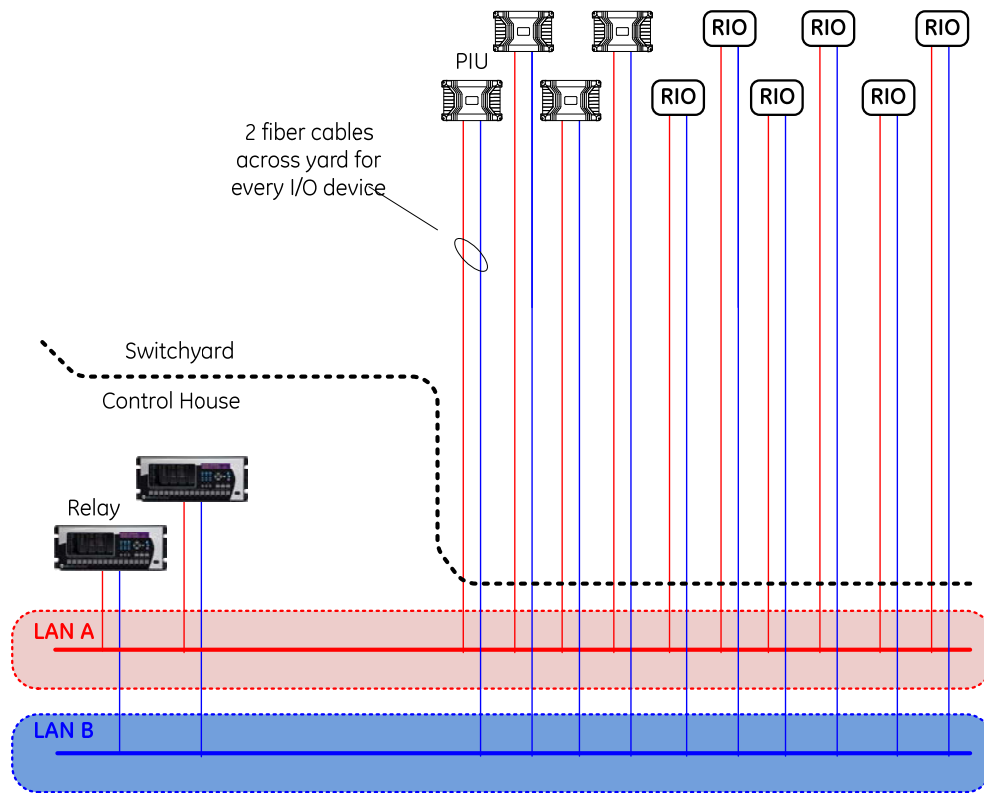

Figure 23: PRP networks for process bus in a line bay

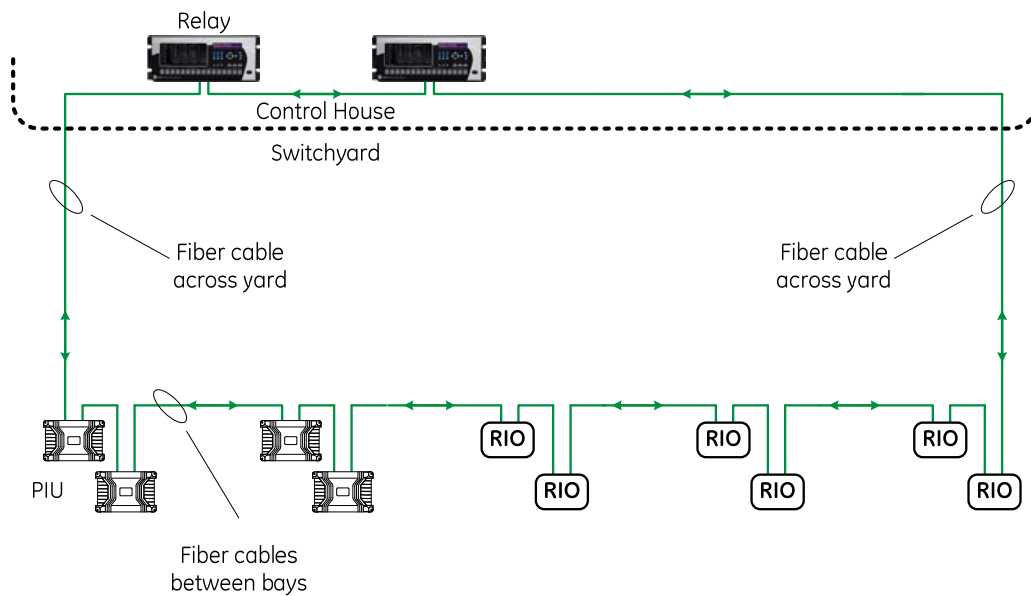

Figure 24: HSR network for process bus in a line bay

#### 5.4.1. PRP for process bus in a line bay

As with the breaker-and-a-half arrangement, the capital cost of the PRP network is going to be a function of the total size of the network. A substation will have multiple line bays connected together.

Cost of cabling across the switchyard is also an important consideration. Traffic shaping to manage bandwidth is critical, and is easily accomplished using VLANs. Sending data from this bay to a device elsewhere in the control house is simply a matter of connecting the device to the PRP networks. Ethernet switches are likely to be located in the control house, though some can be located in the switchyard to control cabling costs.

#### **5.4.2. HSR for process bus in a line bay**

**The capital cost for HSR depends on the number of devices to connect, and the bandwidth required.**

Figure 24 shows a single HSR ring to connect process interface units and relays together for this line bay. A 100 Mb network has adequate bandwidth for this specific scenario. However, sharing data from this line bay to other devices will require meshed HSR networks, significantly increasing complexity and cost. Once again, the cost of installing fiber optic cables between devices in the switchyard can be significant. Testing may add significant operating costs, depending on the requirements of PTWs in regards to equipment outages. It is likely, however, that the entire bay will be shut down during equipment maintenance, so jumpering the HSR network during testing will not be necessary.

#### **5.4.3. Appropriate network configuration for process bus in a line bay**

Both PRP and HSR can be used for process bus at the bay level. Neither solution is ideal. Capital costs should be similar for both PRP and HSR. PRP is simpler due to the use of networks that can easily be expanded, bandwidth can be easily managed and increased, and sharing data is a matter of adding connections to the network. Maintenance costs may be better with PRP, because there should be no special requirements introduced by a PTW.

The most appropriate choice is actually a hybrid system, combining both PRP and HSR networks, in a configuration like that of Figure 25. The HSR ring becomes an independent ring of only the process bus I/O devices contained in the line bay. The network adds two RedBoxes to connect the HSR ring to redundant PRP networks to share data throughout the switchyard. So every bay has its own HSR ring, connected to station wide PRP networks. This addresses bandwidth concerns, traffic management and traffic shaping needs, and provides a simple method for isolation for test. This hybrid system is easily expandable, as adding a line bay means only connecting another HSR to the PRP networks, and connecting the protection devices to the PRP networks as well.

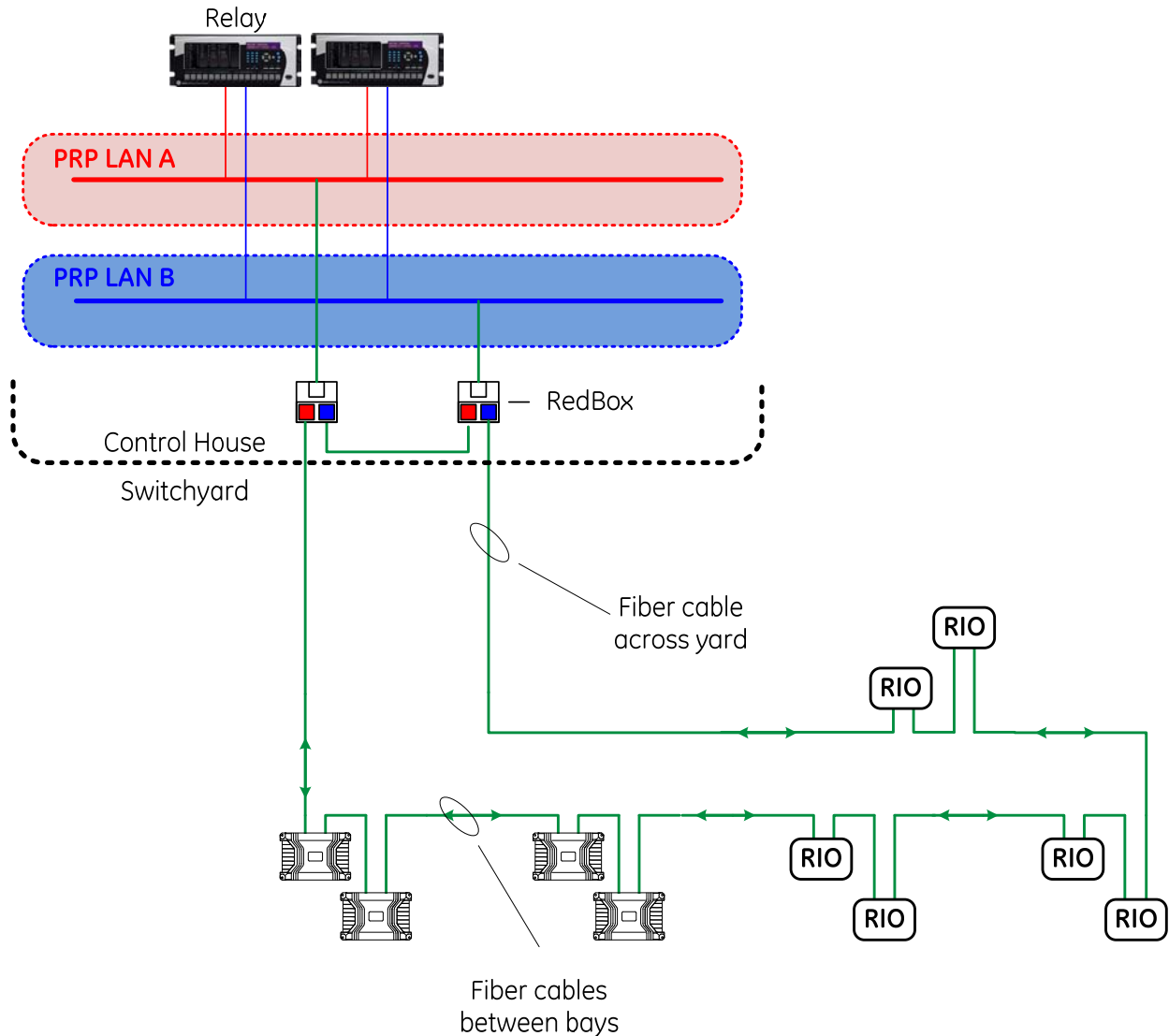

Figure 25: Line bay HSR network connected to station wide PRP networks

## 6. Other aspects of high-availability networks

There are other aspects to consider when applying high-availability networks that are beyond the scope of this paper. The first of these is integrating legacy devices and legacy networks into a high-availability network. It is possible to combine devices connected on a legacy network into one of the high-availability networks. This takes some careful thought and careful design of the communications system. The general process is to use VLAN tagging, and connect legacy devices as SANs to one of the networks. This is an obviously easier task connecting to a PRP network than to HSR, because the PRP networks are traditional LAN networks.



The second aspect to consider is that of time synchronization. The general industry trend is towards providing time synchronization through the communications network, using methods such as NTP or IEEE 1588. NTP will not provide the required level of accuracy working through either PRP or HSR. The NTP clocks in end devices are not designed or intended to work with duplicate messages or duplicate master clocks. IEC 62439-3 specifically calls out IEEE 1588 as the only permissible time synchronization method through the network. This, however, places some requirements on end devices. Any HSR node must be a 1588 Transparent Clock. HSR nodes will need to treat the duplicate 1588 synchronization frames as coming from different master clocks. Depending on the location of the end device, there can be significantly different time delays for the two paths around the network. With PRP, the simplest solution is to connect 1588 Master Clocks as SANs to each of the networks, and have end devices simply treat them as the two different Master Clocks that they are. Connecting a 1588 Master Clock as a DANP to both networks requires that the clock in the end device treat the duplicate frames as coming from different Master Clocks.

## 7. Conclusions

The rise of the “fully digital substation”, and the growing use of digital communications for all data, is driving the need for high-availability networks in substations. IEC 61850 applications are now sending mission-critical data through GOOSE messages and sampled value messages. Simple ring network’s and dual LANs are not adequate for the task of high-availability in these situations. The IEC 62439-3 Standard defines two methods for high-availability networks: PRP and HSR. Both can be applied successfully, the challenge is to identify which one is appropriate for specific application.

PRP is the best choice for large or complex applications. The ability to do traffic shaping, and easily support testing and maintenance activities required by permit the work regulations, give PRP the advantage in performance and total cost of ownership. HSR is the best choice for small, simple, or self-contained systems like distribution substations, where there is no additional operating costs introduced by complexity of testing. The expectation for the future in large substations is to see a hybrid system that combines both PRP and HSR networks together. HSR rings for small self-contained sections of the substation, such as process bus I/O devices in a line bay. These HSR rings are tied together with a station-wide PRP network. This may give the best combination of performance, availability, and cost in the future.

## 8. References

- [1] IEEE Standard 802.1D-2004, “IEEE Standard for Local and Metropolitan Area Networks—Media access control (MAC) Bridges (Incorporates IEEE 802.1t™-2001 and IEEE 802.1w™)”, IEEE, New York, NY
- [2] IEEE Standard 802.1w-2001 “IEEE Standard for Information Technology -Telecommunications and Information Exchange Between Systems - Local and Metropolitan Area Networks - Common Specifications - Part 3: Media Access Control (MAC) Bridges: Amendment 2 - Rapid Reconfiguration”, IEEE, New York, NY
- [3] IEC International Standard “Communication networks and systems in substations - Part 5: Communications requirements for functions and device models”, IEC Reference number IEC/TR 61850-5:2003(E), IEC, Geneva, Switzerland.

- [4] IEC International Standard "Industrial communication networks – High availability automation networks – Part 3: Parallel Redundancy Protocol (PRP) and High-availability Seamless Redundancy (HSR)", IEC Reference number IEC 62439-3:2012, IEC, Geneva, Switzerland.
- [5] ISO/IEC/IEEE 8802-3-2014 "ISO/IEC/IEEE International Standard for Ethernet"

## Biographies

**Rich Hunt** is a Market Development Leader with GE Digital Energy, focusing on IEC 61850 solutions and strategies for protection and control systems. Rich has over 25 years' experience in the electric power industry with both utilities and solution providers. Rich earned the BSEE and MSEE from Virginia Tech, is a Senior Member of IEEE, a member of the Main Committee of the IEEE Power System Relaying Committee, the U.S. representative to the CIGRE B5 Technical Committee, and is a registered Professional Engineer.

**Bogdan Popescu** is a Subject Matter Expert for digital substation systems responsible for leading the definition of system level requirements and coordination of functions and features across product lines, and he participates in research and evaluation of technologies applicable for advancement of GE's Grid automation portfolio. Bogdan has 28 years' experience in the electric power industry working for utility and solution providers across Europe, North America and Middle Eastern markets. Bogdan earned his MSEE in Data Acquisitions from the Faculty of Electronics and Telecommunications in Bucharest, Romania, is a member of IEEE, and is a registered Professional Engineer in Alberta, Canada.